

## AUDIO SYSTEM

The audio system for the vehicle comes in three distinct levels:

- radio preparation, it only includes connections and cables.
- standard radio (with CD / MP3 player), complete with the audio system and 6 or 8 speakers;
- BOSE "Hi-Fi" sound system (with 9 speakers, subwoofer and multi-channel amplifier with the standard car radio);

There is also the possibility of a Blue&Me infotainment system with Bluetooth radio telephone function and media player,

[See descriptions 5570 ACCESSORIES](#)

"Blue & Me" version

or Radio Nav navigation system

[See descriptions 5580M ON-BOARD NAVIGATOR](#)

A PND (Portable Navigation Device) setup is offered as an alternative. The device can be installed in the middle of the dashboard.

### General specifications of the standard system

The system comprises 6 speakers as illustrated in the diagram:

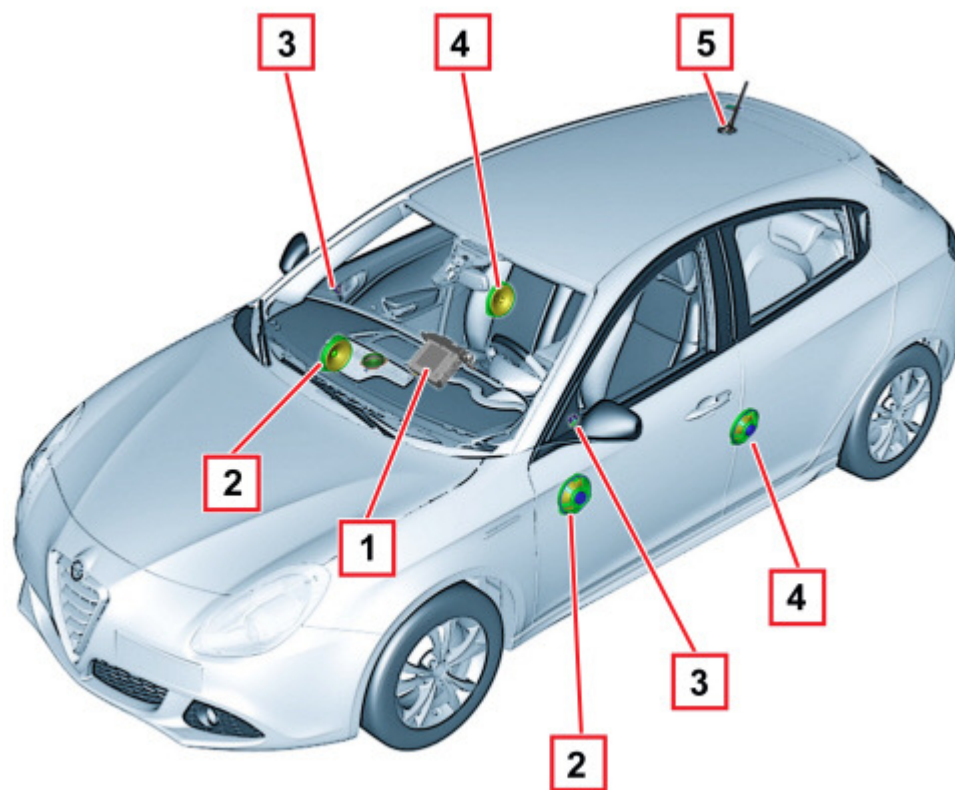

- 1 - Radio
- 2 - Front door midwoofer speakers
- 3 - Tweeter front speakers
- 4 - Midwoofer rear speakers
- 5 - Aerial

#### Front speakers

They are 165 mm diameter 40W mid-woofer speakers located in the front doors.

They are designed to reproduce medium-low frequencies.

The technology used for these components (water resistant) means that they can withstand jets of water inside the door without suffering damage.

It is a speaker with a paper membrane, plastic support (ABS), ferrite magnet and aluminium coil support.

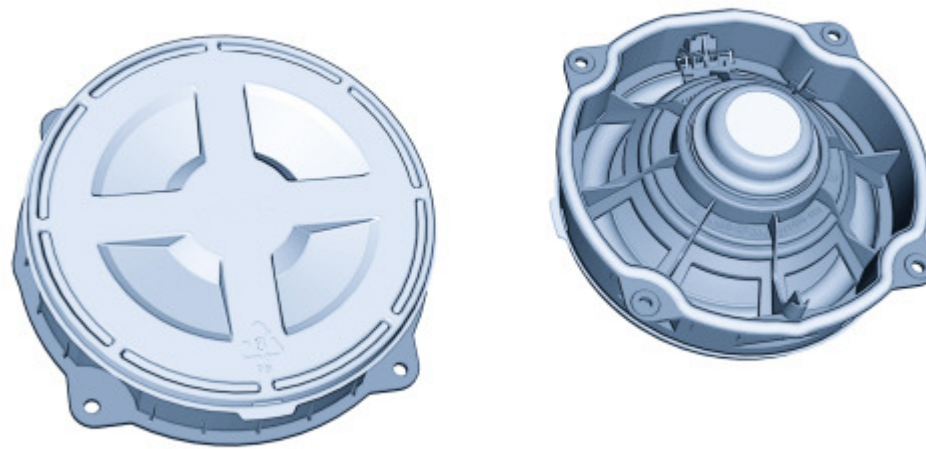

### Front tweeters

These are 30-W tweeter speakers located in the door panel upper part, designed to reproduce higher frequencies. It is a "dome" tweeter with a polycarbonate cone, ferrite magnet and copper coil support.

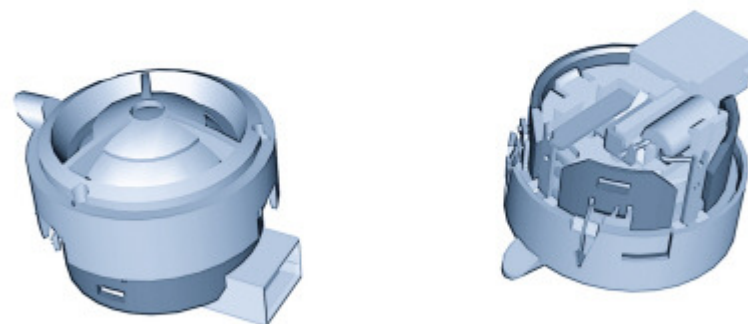

### Rear speakers

These are 165 mm diameter, 40W full-range speakers located in the rear doors capable of reproducing the entire audio frequency range. These components are also produced using water resistant technology. It is a dual cone speaker with a paper diaphragm, plastic (ABS) support, ferrite magnet and aluminium coil support.

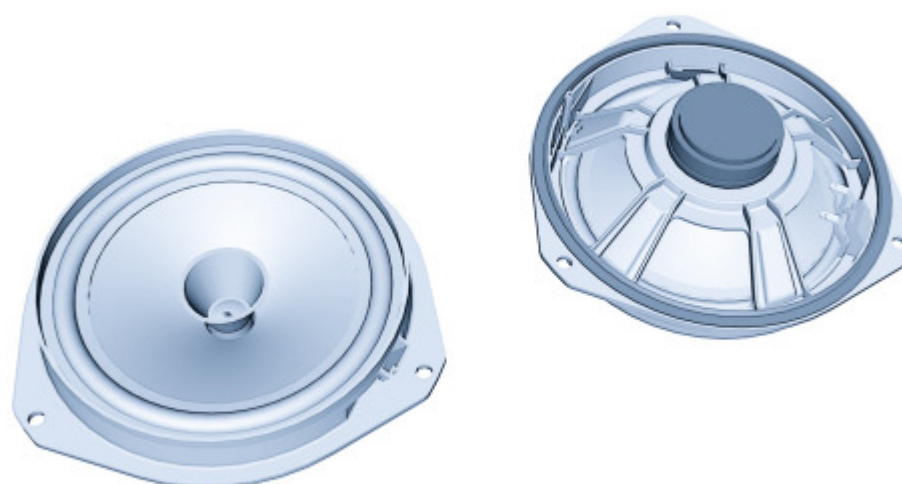

 A system with more accessories is supplied upon demand, including:  
- tweeters (like the front ones) in the rear doors as well;

- midwoofer (like the front ones) instead of full-range speakers in the rear doors.

## Aerials

The structure of the aerials consists of:

- AM/FM1 stylus aerial mounted at the back in the centre of the roof;
- FM2 aerial which uses the heated rear windscreen heating elements;
- navigation aerial (GPS) mounted on the roof (used with the Radio Nav);

[See descriptions 5580M ON-BOARD NAVIGATOR](#)

The **FM2** aerial on the rear window is used in addition to the stylus aerial when the radio or the radio navigator are provided with the PHASE DIVERSITY function. This function is based on a signal processor inside the radio which exploits the double antenna for tuning to the station with the best available signal instant by instant.

This considerably improves the quality of the FM signal received in all limit conditions, such as for example multipath distortions or co-channel interference.

The FM2 signal arrives from the heated rear windscreen filaments reaching a dedicated amplifier and goes to the radio module via a coaxial cable.

The **FM1** signal comes from the stylus aerial which, on the version with radio navigator, includes the GPS aerial and a dedicated amplifier incorporated in the base of the aerial; it is then sent, through a coaxial cable, to the radio module.

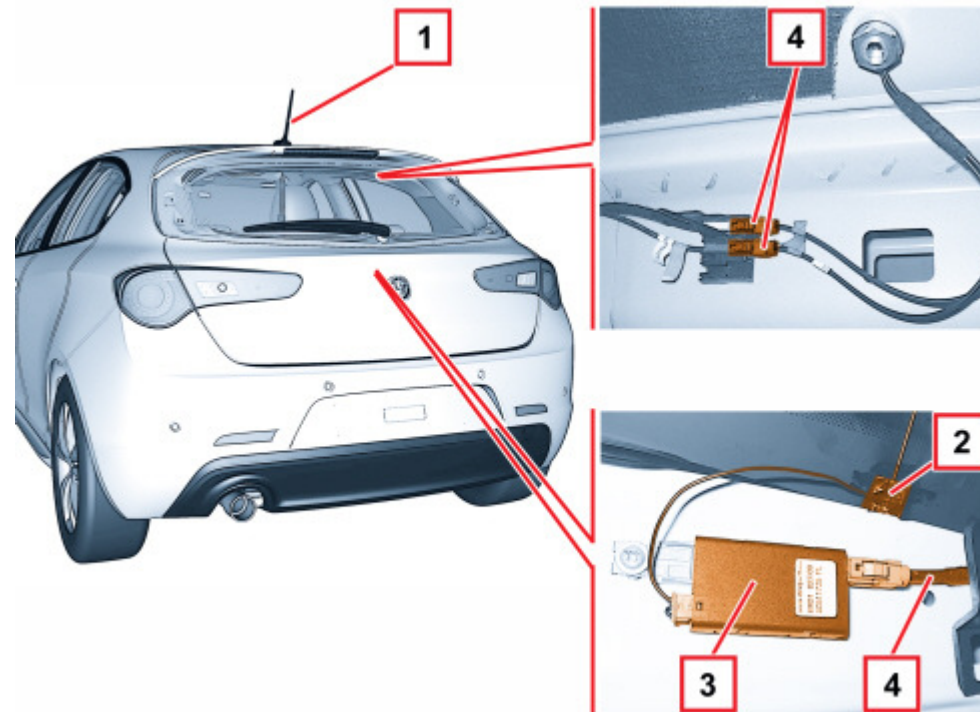

- 1 - AM/FM1, GPS stylus aerial
- 2 - FM2 aerial connection incorporated in the heated rear windscreen
- 3 - FM2 amplifier
- 4 - aerial leads to radio module

## Bose hi-fi sound system

A BOSE Hi-Fi Sound System is available on request.

The BOSE audio system features aggressive sound particularly suited to young people.

The system is composed of 10 speakers, a subwoofer box for deep bass and a power amplifier.

The system has been specially developed for the car: the acoustic properties of the passenger compartment have been carefully studied so that the amplifier and the speakers are ideally suited to the car itself: optimum listening is available in any part of the passenger compartment.

### Bose system

The BOSE hi-fi system for the model is controlled by a 8800 model amplifier with 4 analogue input channels and 7 stereo output channels.

The amplifier controls 9 speakers with different equalizers, delays and limiters.

A sub-woofer with specific power amplifier is arranged in the spare wheel compartment.

Four mid-woofers (diameter 6.5") are arranged in the front and rear doors.

Four tweeters are installed in the front and rear doors.

Two front tweeters are controlled in independent manner by two specific channels optimised for crossover and balance.

There is also a centre fill in the middle of the dashboard to improve the tone and balancing of the sound level.

### Front and rear speakers

They are mid-woofer speakers, diameter 165 mm, with foamy contour, plastic cone, neodymium magnet and aluminium membrane. They are positioned in the front and rear doors.

### Front and rear tweeters

These are dome tweeters with neodymium magnet, plastic structure, paper cone and aluminium membrane.

They are located at the top of the door panels.

### Centre fill speakers

The centre fill has a fabric cone with a steel structure, a neodymium magnet and an aluminium sound source.

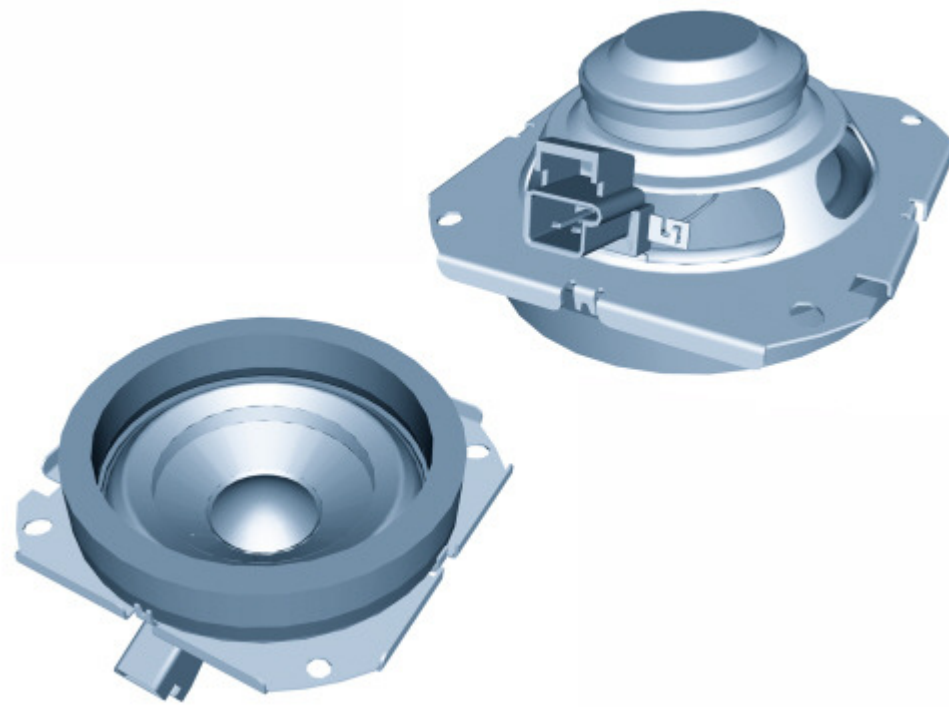

**Subwoofer**

The bass-reflex subwoofer box contains a 15" diameter speaker with its own amplifier, mod. 1000, for playing the deepest frequencies and is positioned in the boot in the spare wheel compartment.



**Amplifier**

The 8 channel amplifier (4 x 37 W rms and 4x18 W rms) controls all speakers.

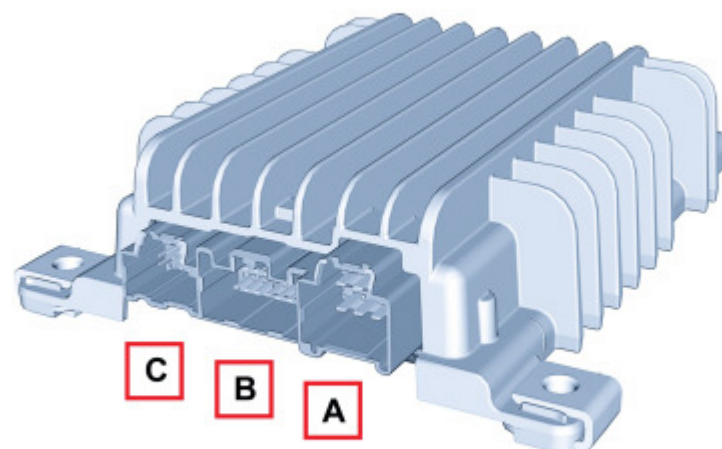

AMPLIFIER CONNECTION PIN OUT  
Connector A

PIN	SIGNAL

A1	Left rear speaker output (-)
A2	Right front speaker output (-)
A3	Left front speaker output (-)
A4	Battery power supply (+)
A5	Left rear speaker output (+)
A6	Right front speaker output (+)
A7	Left front speaker output (+)
A8	Chassis earth

Connector B

PIN	SIGNAL
B1	Centre fill output (-)
B2	Centre fill output (+)
B3	Left front tweeter output (-)
B4	Left front tweeter output (+)
B5	Right front tweeter output (-)
B6	Right front tweeter output (+)
B7	Right rear speaker output (-)
B8	Right rear speaker output (+)
B9	Not connected
B10	Not connected
B11	Not connected
B12	Preparation for mute signal (N.C.)
B13	Not connected
B14	Not connected
B15	Subwoofer bassbox speaker output (+)
B16	Subwoofer bassbox speaker output (-)

Connector C

PIN	SIGNAL
C1	Microphone positive signal (NC)
C2	Not connected
C3	Not connected
C4	Right rear speaker input (-)
C5	Left rear speaker input (-)

C6	Right front speaker input (-)
C7	Left front speaker input (-)
C8	Hi-fi amplifier enablement (input)
C9	Microphone negative signal (NC)
C10	Subwoofer bassbox speaker enablement (output)
C11	Not connected
C12	Right rear speaker input (+)
C13	Left rear speaker input (+)
C14	Right front speaker input (+)
C15	Left front speaker input (+)
C16	Car speed signal (N.C.)

The amplifier is located in the luggage compartment, on the passenger's side.

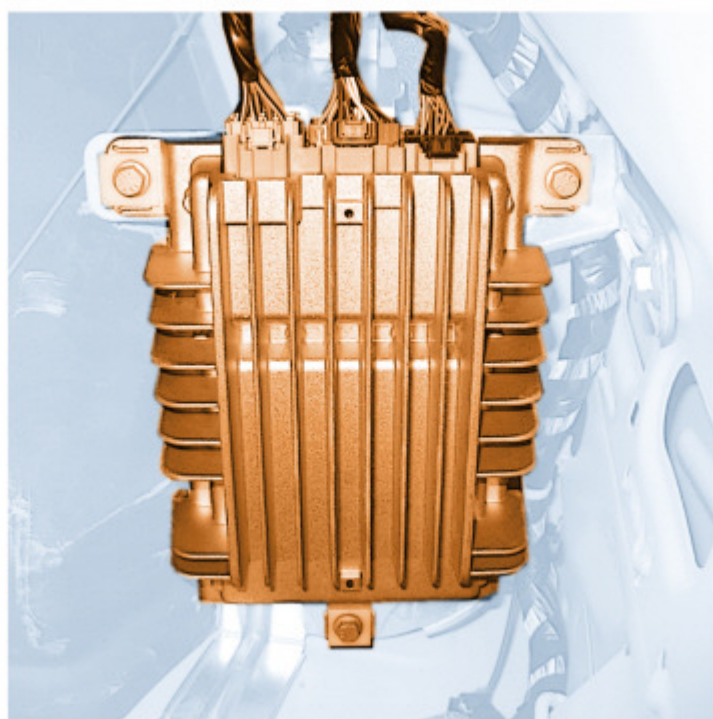

## RADIO

The Radio Receiver Node (RRN) is in a DIN housing, usually located in the middle of the dashboard.

All versions are prepared for connection with the low speed CAN interface at the B-CAN to allow dialogue with the other system nodes. The following are transferred via this interface:

- Anti-theft code;
- On control (for switching-off logic);
- Speed dependent volume control;
- Lighting control;
- Remote controls from the steering wheel, where fitted;
- Repetition of radio information at control panel.
- Interface with Blue&Me, where fitted.
- Interface with AUX socket, where fitted.

## Characteristics

### Main features

- Music audio power: 4x30W
- 7 band graphic equalizer
- Digital tuner with variable selectivity.
- Built-in, large, alphanumerical display (2 lines with 12 characters for RDS functions + control symbol)
- Easily operated menu for adjusting radio settings or any outside interfaces
- Mute function produced by pressing the MUTE button briefly
- Soft mute, during radio source/station changing operations
- Volume adjustment depending on the vehicle speed (selected using the menu)
- Radio switching off timer adjustment (immediately or 20 minutes after the key off)
- Phantom-Power aerial power supply.

- Remote control from the steering wheel
- Possibility of interface with the CD-Changer
- BOSE Hi-fi system active control, where fitted
- Connection to Blue&Me hands-free system
- Anti-theft function.

### Radio specifications (radio cd/mp3)

- Digital tuner with variable selectivity
- FM multipath detector
- Possibility of selecting HICUT function (High-Cut:= dynamic reduction of treble if RF signal is poor)
- Automatic FM stereo activation
- AM noise cancellation
- Autostore (automatic memorizing of radio stations with best signal)
- RDS (Radio Data System) with EON, AF (alternative frequencies), PI, PS, TA, TP, PTY and REG function (that can be selected by the user)
- Automatic and manual search for stations
- Possibility of adjusting Local/Distance for automatic frequency search- Possibility of programming:
- Possibility of programming:
  - . 18 FM stations (6 of which can be memorized through autostore).
  - . 6 MW stations
  - . 6 LW stations

A radio turning frequency setting procedure is provided to switch between EUROPE (default) or SOUTH AMERICA or USA settings, if needed.

 To go from one configuration to the other hold buttons “FM” and “1” pressed for the long time within 5 SECONDS AFTER TURNING THE RADIO ON.

The configuration will appear when the radio is switched on, as shown below.

### Mp3 cd specifications

- Motorized loading and ejection
- Select previous (next) track
- Up/down track selection
- Pause
- FF / F-REW
- MP3 Display (file, ID3-TAG information, track time elapsed, name of the file)
- Reading of printed audio or information CDs, CD-R and CD-RW.

### Audio specifications

- Bass
- Treble
- Balance
- Fader
- Loudness
- Mute
- 7 band graphic equalizer: Preset (default), Rock, Jazz, Classic, User (can be personalized)
- Speed Volume Control
- Possibility of interface with outside amplifier (if available).

### Radio front section



### Display

The alphanumerical display is large with 20 characters for RDS functions and control symbols  
The set configuration (e.g. EUROPE) will appear when the radio is switched on.

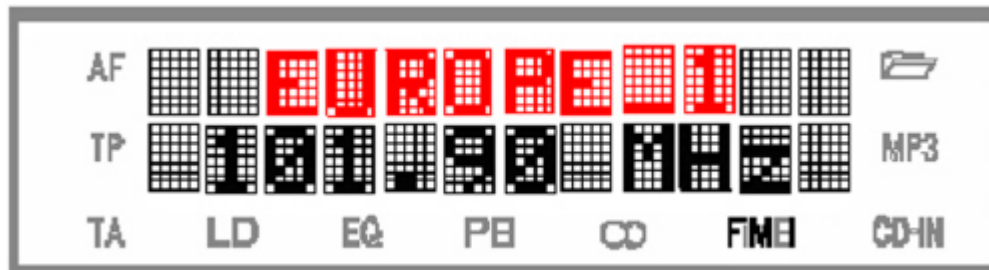

## Remote controls on the steering wheel

There may be remote controls on the steering wheel for the radio:



## Anti-theft code

The radio is installed in production and connected to the CAN to establish communication with the Body Computer, memorizing an anti-theft code known as an exchange code.

At each subsequent Key On (and even if the battery is disconnected), an automatic authentication procedure is repeated: the words "CAN CHECK" appear in the radio display: if the Exchange Code check is positive, the system begins to operate. If the codes compared are not the same, a message appears on the display asking the user to enter a manual code (Master Code - 4-figure code from 1111 to 6666) that is shown on the radio code card.

 The Master Code is pre-programmed in production and different for each radio; it is also different from the Exchange Code.

## Entering the password

When the radio is switched on, if the password is requested, the display will show "CODE" for about 2 seconds followed by four dashes "----".

The secret code is made up of four digits from 1 to 6, each corresponding to one of the dashes.

To enter the first digit of the code, press the button corresponding to the pre-selected stations (from 1 to 6). Enter the other code digits in the same way. If the four figures are not entered within 20 seconds, the display again shows the message "CODE" for 2 seconds and then the four dashes "----". If this occurs, it is not considered an incorrect code entry.

After entering the fourth digit (within 20 seconds), the car radio will work.

If an incorrect code is entered, the radio will emit a sound and the display will show the word CODE for 2 seconds and then four dashes "----" to notify the user of the need to enter the correct code.

After three attempts the radio considers the last code as "incorrect"; each time the user enters an incorrect code, the waiting time increases gradually (1 min, 2 min, 4 min, 8 min, 16 min, 30 min, 1h, 2h, 4h, 8h, 16h, 24h) to a maximum of 24 hours. The waiting time is shown on the display with the words "RADIO BLOCKED, WAIT".

After the writing has disappeared it is possible to start the procedure of entering the code again.

## Code card

This document certifies the ownership of the car radio. The Code Card contains the model of the radio, the serial number and the secret code.

 The manual Master Code input procedure is necessary only if: the Body Computer is replaced or a radio already used on another vehicle with a CAN is installed.

 A "new" radio (which has never been fitted on other vehicles) can be fitted following an automatic authentication procedure without entering the master code manually.

## Operation at key off

The following function can be selected using the radio setup menu:

- if the radio is on at the time of the key off, it is automatically switched off after 20 minutes (or at another value selected using the menu); it can be kept on for a further 20 minutes by pressing the ON button.

The following can be selected in the setup menu under the item "---IGNITION-TIMER---".

"-OFF-AFTER-00-MIN--"

"-OFF-AFTER-20-MIN--"

# Connectors

Rear view:

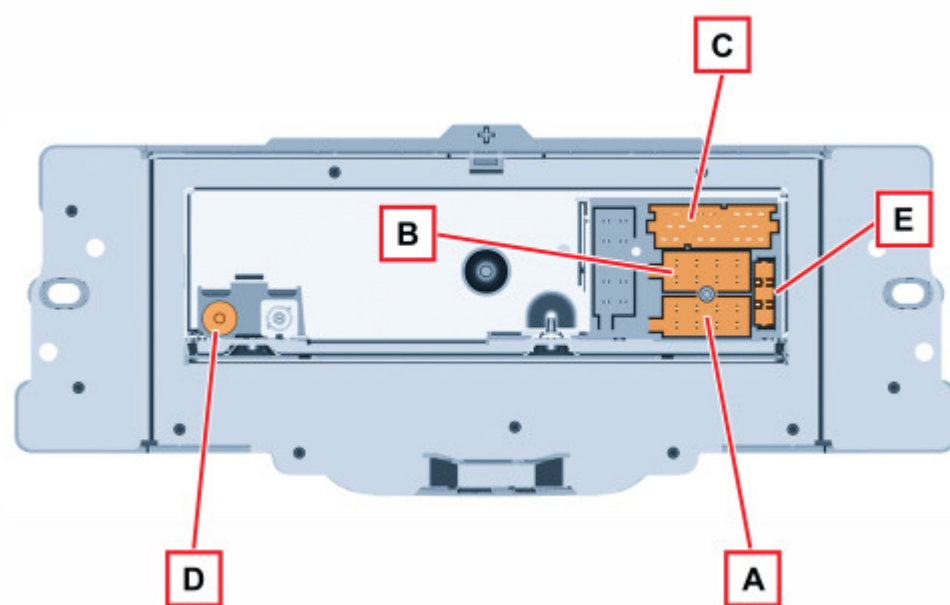

- A - Power supply connector
- B - Speaker output connector
- C - Auxiliary functions connector
- D - Aerial connection
- E - Housing for 10 A fuse

## Connector pin out

Connector A:

Pin	Function
A1	B Can B (high)
A2	Positive amplifier recognition signal
A3	B Can A (low)
A4	+30 power supply from F36
A5	Power supply for subwoofer enabling
A6	Controls lighting power supply
A7	+15 power supply from F51
A8	Earth

Connector B:

Pin	Function
B1	Right rear speaker +
B2	Right rear speaker -
B3	Right front speaker +
B4	Right front speaker -
B5	Left front speaker +
B6	Left front speaker -
B7	Left rear speaker +

B8	Left rear speaker -
----	---------------------

Connector C:

Pin	Function
C1	Left AUX signal
C2	Right AUX signal
C3	AUX signal

Connector E connection with CDC (optional):

Pin	Function
E13	CDC data IN
E14	CDC data OUT
E15	Permanent power supply for CDC
E16	Positive signal for CDC power supply enablement
E17	CDC data GND
E18	CDC audio GND (or AUX GND)
E19	L input for CDC (or AUX socket)
E20	R input for CDC (or AUX socket)

## Aux socket

In the versions with "Blue&Me", an external source can be connected to the AUX input, installed together with the "Media Player" USB port used by the "Blue&Me" system.

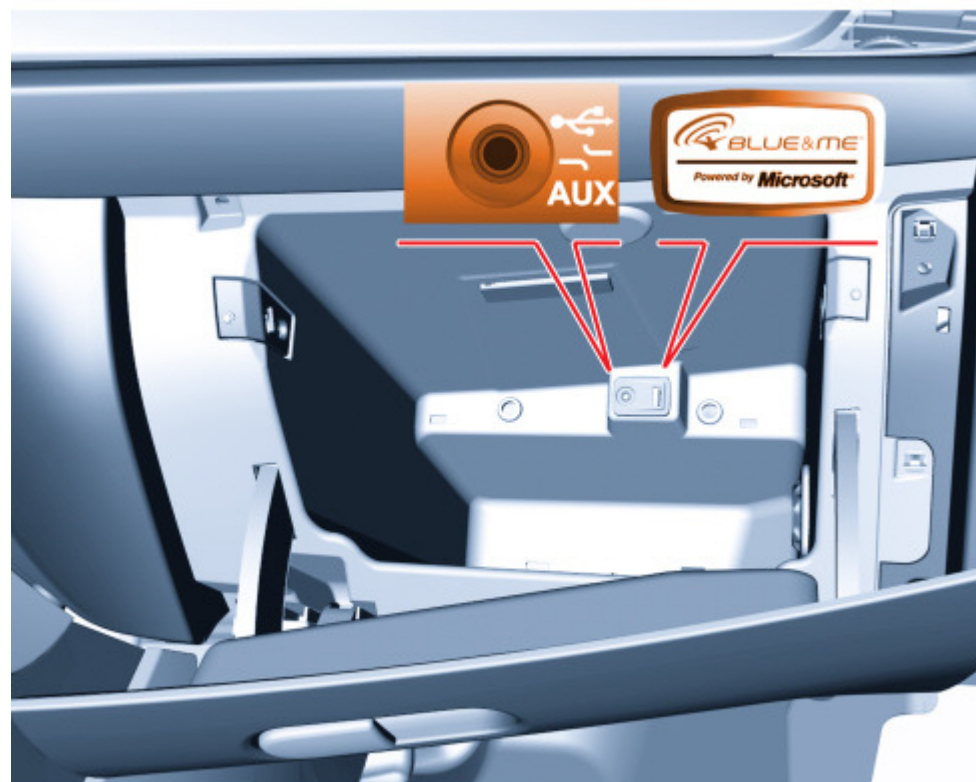

## Aux mode

To activate the AUX source, press the MEDIA button or the SRC steering wheel control several times till the corresponding source is displayed. The functions of the device connected with the AUX socket are directly managed by the device itself; it is not possible to change track/folder/playlist with radio or steering wheel controls.

In AUX mode the "AUX Offset" function is available which allows the alignment of the portable device volume to the one of the other sources.