

SPECIFICATIONS

2.0L Engine

Description	Capacities	Type	Part Number	Global Part Number
Engine Oil With Filter	5.5 Quarts / 5.2 Liters	Mopar API SN PLUS Certified SAE 0W-30 Full Synthetic Engine Oil CAUTION: Failure to use the recommended SN PLUS or equivalent oil can cause engine damage not covered by the vehicle warranty.	68291576AA	N/A
Cooling System *	Engine 2.2 Gallons / 8.6 Liters Intercooler 1.1 Gallons / 4.3 Liters	CUNA NC 956-16 ASTM D3306 MS.90032 Use rate 50% Not mixable with different formulation products. (*) For particularly harsh climate conditions, a mixture of 60% product and 40% distilled water is recommended.	68163848AB	68163848GB
Fuel Selection	15.3 Gallons / 58 Liters	N/A	—	—
Spark Plugs	GAP	We recommend you use MOPAR Spark Plugs.	68292346AA	—
	0.024 – 0.025 in / 0.60 – 0.65 mm			
* Includes heater and coolant reservoir filled to MAX level.				
** Reference only, not adjustable.				

2.9L Engine

Description	Capacities	Type	Part Number	Global Part Number
Engine Oil With Filter	7.2 Quarts / 7 Liters	SAE 0W-40 Pennzoil Ultra API SN FPT 9.55535-Z2 MS-12991	68171066PB	68171066GA

Description	Capacities	Type	Part Number	Global Part Number
Cooling System *	2.95 Quarts / 11.2 Liters Intercooler 1.4 Gallons / 5.5 Liters	CUNA NC 956-16 ASTM D3306 MS.90032 Use rate 50% Not mixable with different formulation products. (*) For particularly harsh climate conditions, a mixture of 60% product and 40% distilled water is recommended.	68163848AB	68163848GB
Fuel Selection	15.3 Gallons / 58 Liters	N/A	—	—
Spark Plugs	GAP	We recommend you use MOPAR Spark Plugs.	68336994AA	—
	N/A			
* Includes heater and coolant reservoir filled to MAX level.				

A/C Refrigerant System

Description	Charge Amounts	Type	Part Number	Global Part Number
A/C System	Refrigerant R1234yf 1.18 lb / .535 kg	N/A	R1234yf 68224028AB	R1234yf 68224028GA

Transmission

Description	Capacities	Type	Part Number	Global Part Number
Automatic	2.0L RWD 9.9 Quarts / 9.4 Liters	ZF 8HP 50 - Synthetic ATF	68218925AA	68218925GA
	2.0L AWD 9.8 Quarts / 9.3 Liters			
	2.9L RWD 9.5 Quarts / 9 Liters			

Chassis Systems

Description	Capacities	Type	Part Number	Global Part Number
RDU 195 Rear Differential Oil	0.9 Quarts / 0.9 Liters	SAE 75W-85 synthetic lubricant FPW9.55550-DA9	68083381AA	68083381GA
RDU 230-TV Rear Differential Oil	Main body: 0.8 Quarts / 0.8 Liters Left TV: 0.5 Quarts / 0.5 Liters Right TV: 0.6 Quarts / 0.6 Liters	SAE 75W-85 API GL-5 synthetic lubricant FPW9.55550-DA8	68083381AA	68083381GA
RDU 230-LSD Rear Differential Oil	0.9 Quarts / 0.9 Liters	SAE 75W-85 synthetic lubricant FPW9.55550-DA9	68083381AA	68083381GA
RDU 210-eLSD Rear Differential Oil (if equipped)	1.4 Quarts / 1.4 Liters	SAE 75W-85 synthetic lubricant FPW9.55550-DA9	68083381AA	68083381GA
RDU 210/215-LSD Rear Differential Oil	1.1 Quarts / 1.1 Liters	SAE 75W-85 synthetic lubricant FPW9.55550-DA9	68083381AA	68083381GA
Front Axle Differential	0.5 Quarts / 0.5 Liters	SAE 75W-80 APL FPW9.55550-DA10	68339072AA	—
AWD System Transfer Case	0.7 Quarts / 0.7 Liters	SAE 75W-80 APL FPW9.55550-DA10	68377611AA	—
Hydraulic Brake System	0.9 Quarts / 0.9 Liters	DOT 4 MS.90039	04549625AD	04549625GD

DRAINING AND FILLING THE ENGINE COOLING SYSTEM

1. Remove the engine belly pan ([Refer to 13 - Frame and Bumpers/Under Body Protection/BELLY PAN/Removal and Installation](#)).

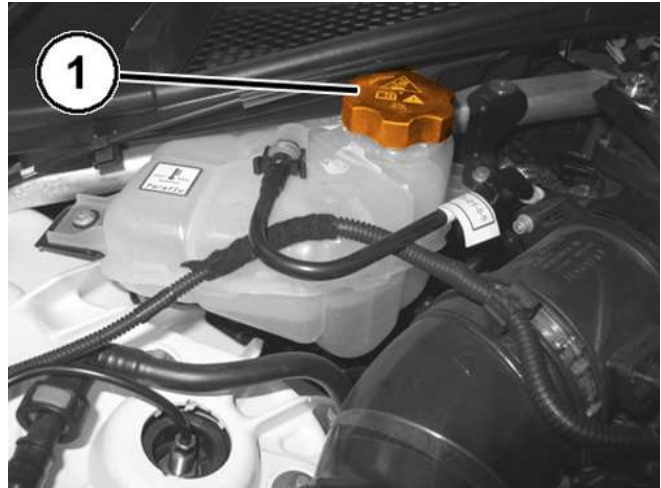

WARNING:

Hot, pressurized coolant can cause injury by scalding.

2. With the engine cold, remove the engine cooling system reservoir cap (1).

3. Position a suitable container for collecting the coolant.

4. Open the engine cooling system radiator drain plug (1).

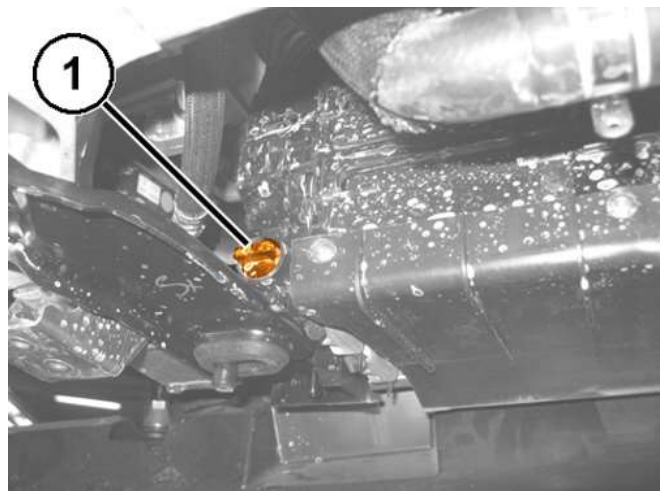

5. When the radiator is completely drained, close the plug.

6. Open the bleed screw on the engine cooling system radiator (1).

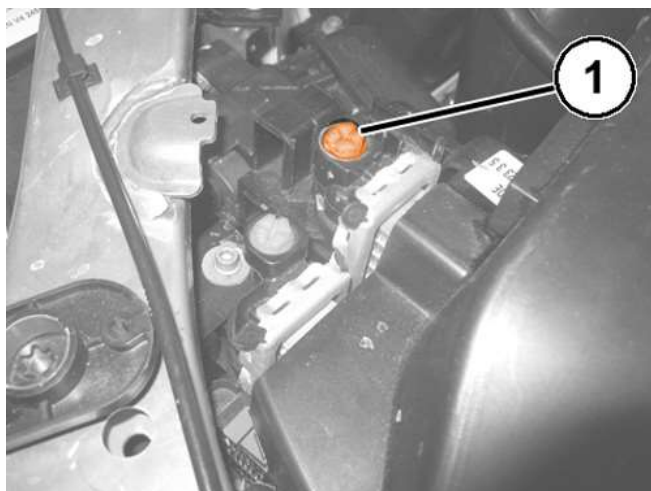

7. Open the bleed screw on the heater core return pipe (1).

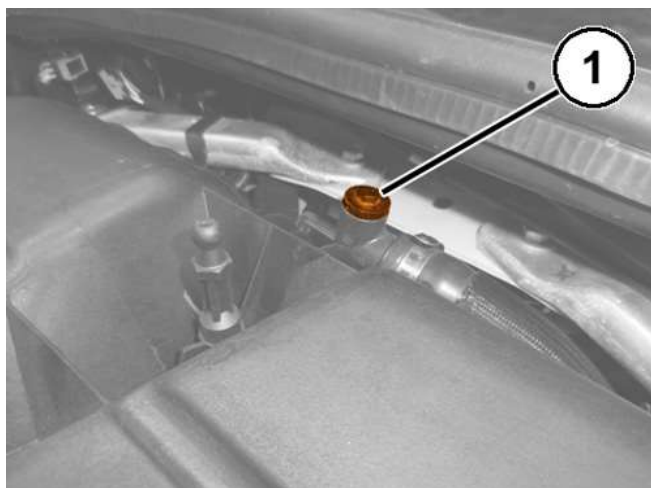

8. Install a measuring container (1) on the filler of the cooling system reservoir.

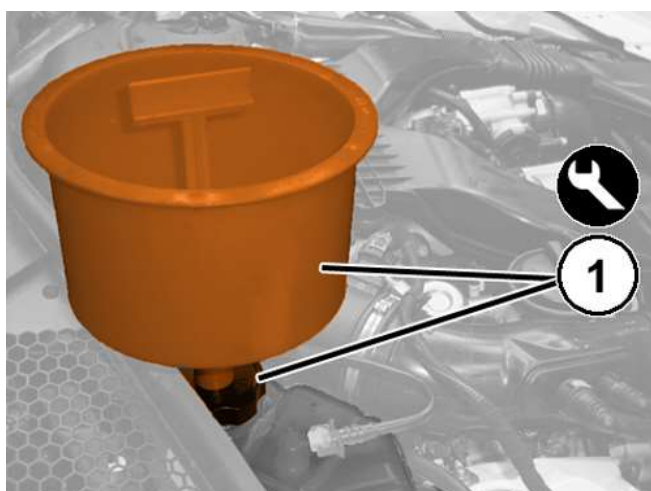

9. Fill the cooling system with prescribed coolant until fluid is coming out of the bleed screws and tighten the bleed screws ([Refer to 04 - Vehicle Quick Reference/Capacities and Recommended Fluids/Specifications](#)).

10. Continue filling until the fluid reaches about 1/3 of the height of the measuring container previously fitted on the cooling system reservoir.

11. At this point, the level in the reservoir will be flush with the filler:
 - Start up the engine and let it idle for about two minutes.

 - Remove the air from the circuit by pumping the accelerator regularly and gradually (every 30 secs) up to a speed of around 2500 rpm. This operation must be carried out so that the thermostat opens and the fan switches on and off at least 3 times.

 - During this operation, keep the climate control system switched off to prevent the fan coming on not due to the heating of the coolant. If there is a noticeable level drop in the expansion tank during this step, switch off the engine, open the cap very carefully and top up the fluid to the MAX mark; then close the cap fully and complete bleeding the air from the system with the engine running.

 - Switch off the engine.

 - After allowing the engine to cool, check that the fluid level is at the MAX mark on the expansion tank.

12. Switch off the engine, remove the measuring container and install the engine cooling system reservoir cap.

13. Install the engine belly pan ([Refer to 13 - Frame and Bumpers/Under Body Protection/BELLY PAN/Removal and Installation](#)).

DRAINING AND FILLING THE TURBOCHARGER COOLING SYSTEM

CAUTION: If customer returned the vehicle with coolant lower than the minimum fill line, all 4 O-rings at the turbo to oil and coolant tubes must be replaced.

1. Remove the engine belly pan ([Refer to 13 - Frame and Bumpers/Under Body Protection/BELLY PAN/Removal and Installation](#)).

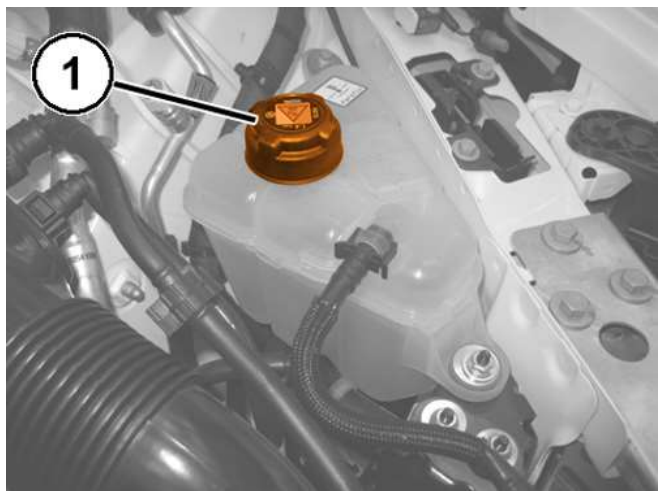

WARNING:

Hot, pressurized coolant can cause injury by scalding.

2. With the engine cold, remove the turbocharger cooling system reservoir cap (1).

3. Position a suitable container for collecting the coolant.

4. Open the turbocharger cooling system radiator drain plug (1).

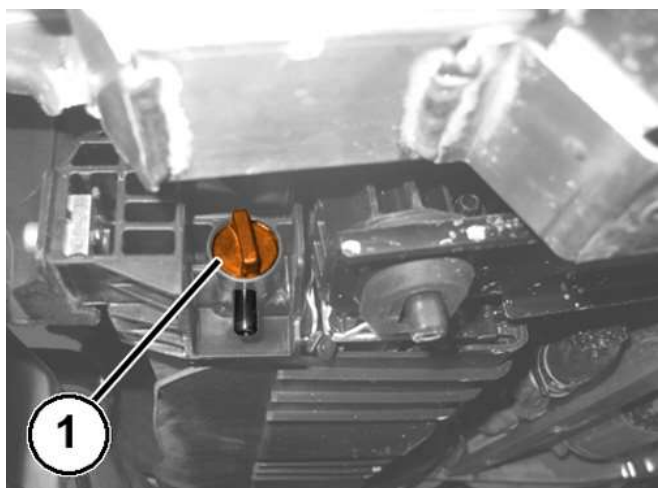

5. When the radiator is completely drained, close the plug.

6. Open the bleed screw (1) on the turbocharger cooling system radiator.

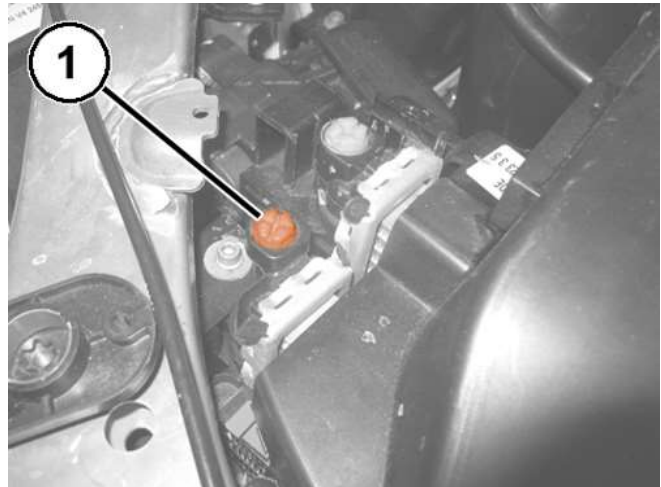

7. Open bleed valve on the engine coolant outlet pipe from the turbo outlet pipe front the turbo charger and keep it open.

8. Pour in the prescribed coolant until fluid is coming out of the bleed screw and tighten the bleed screw ([Refer to 04 - Vehicle Quick Reference/Capacities and Recommended Fluids/Specifications](#)).

9. When refilling is complete, the coolant level will be flush with the filler.

10. Install the turbocharger cooling system reservoir cap.

11. Connect the diagnosis equipment to the vehicle diagnosis socket, activate the electric pump at 75% of its power and let it run for about 10 minutes. Then change the solenoid valve position to 3-way and in the meantime continue to bleed air with the electric water pump activated to 75% for 5 more minutes.

12. If there is a noticeable drop in level in the supply reservoir during this stage, switch off electric pump, open the cap very carefully and top up the fluid to the MAX level. Then close the cap fully and complete bleeding the air from the system, keeping the electric pump powered at 75%.

13. With the pump powered, slowly unscrew the radiator bleed screw until coolant comes out, then retighten. Repeat for the Turbo line bleed screw. (1)

14. Then switch off the power to the electric pump.

15. Install the engine belly pan ([Refer to 13 - Frame and Bumpers/Under Body Protection/BELLY PAN/Removal and Installation](#)).



0703152736

07 - Cooling/Standard Procedure

COOLANT AIR EVACUATION

WARNING:

ANTIFREEZE IS AN ETHYLENE GLYCOL BASE COOLANT AND IS HARMFUL IF SWALLOWED OR INHALED. IF SWALLOWED, DRINK TWO GLASSES OF WATER AND INDUCE VOMITING. IF INHALED, MOVE TO FRESH AIR AREA. SEEK MEDICAL ATTENTION IMMEDIATELY. DO NOT STORE IN OPEN OR UNMARKED CONTAINERS. WASH SKIN AND CLOTHING THOROUGHLY AFTER COMING IN CONTACT WITH ETHYLENE GLYCOL. KEEP OUT OF REACH OF CHILDREN. DISPOSE OF GLYCOL BASED COOLANT PROPERLY. CONTACT YOUR DEALER OR GOVERNMENT AGENCY FOR LOCATION OF COLLECTION CENTER IN YOUR AREA. DO NOT OPEN A COOLING SYSTEM WHEN THE ENGINE IS AT OPERATING TEMPERATURE OR HOT UNDER PRESSURE; PERSONAL INJURY CAN RESULT. AVOID RADIATOR COOLING FAN WHEN ENGINE COMPARTMENT RELATED SERVICE IS PERFORMED; PERSONAL INJURY CAN RESULT.

WARNING:

WEAR APPROPRIATE EYE AND HAND PROTECTION WHEN PERFORMING THIS PROCEDURE.

CAUTION: Failure to purge air from the cooling system can result in an overheating condition and severe engine damage.

NOTE: The preferred method to remove air from the cooling system is to use [Tool, UView Airlift™ Cooling System Refill 399-550000](#) .

Evacuating or purging air from the cooling system involves the use of a pressurized air operated vacuum generator. The vacuum created allows for a quick and complete coolant refilling while removing any air pockets present in the system components.

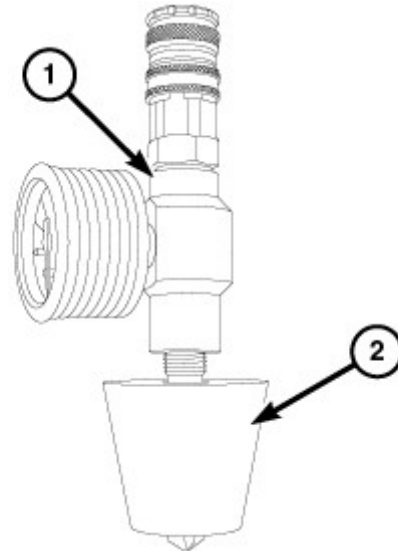

2321100

NOTE: The service area where this procedure is performed should have a minimum shop air requirement of 80 psi (5.5 bar) and should be equipped with an air dryer system.

NOTE: For best results, the radiator should be empty. The vehicle's heater control should be set to the heat position (ignition may need to be turned to the ON position but do not start the engine).

1. Refer to the service equipment tool's operating manual for specific assembly steps.
2. Choose an appropriate adapter cone that will fit the vehicle's cooling system filler neck.
3. Attach the adapter cone (2) to the vacuum gauge (1).

4. Make sure the vacuum generator / venturi ball valve (3) is closed and attach an airline hose (2) (minimum shop air requirement of 80 psi / 5.5 bar) to the vacuum generator / venturi (1).

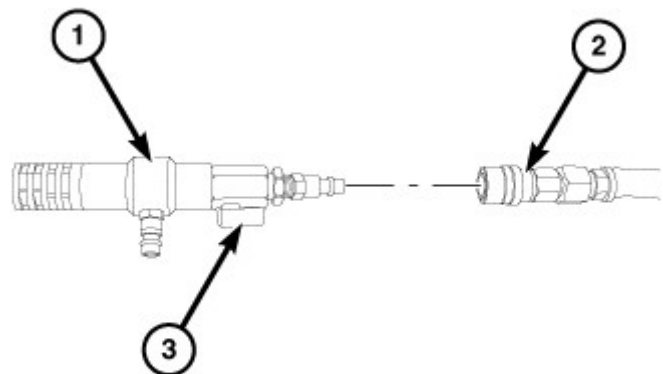

5. Position the adaptor cone/vacuum gauge assembly on the filler neck. Make sure that the adapter cone is sealed properly.

2321148

6. Connect the vacuum generator / venturi (2) to the positioned adaptor cone/vacuum gauge assembly (1).

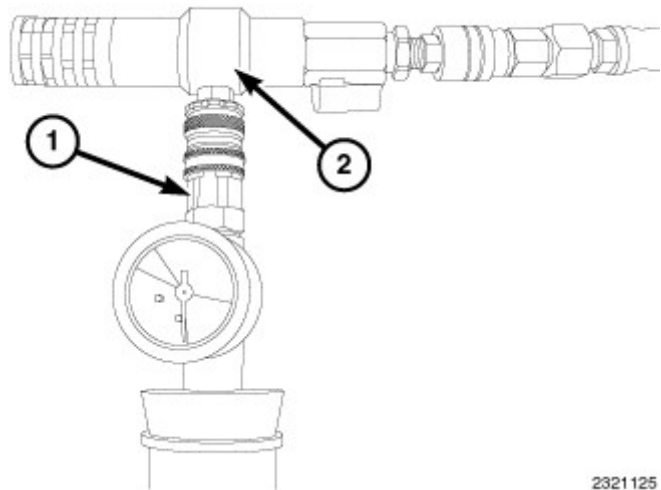

2321125

NOTE: Do not bump or move the assembly as it may result in loss of vacuum.

7. Open the vacuum generator / venturi ball valve.

NOTE: If a strong vacuum is being created in the system, it is normal to see the radiator hoses collapse.

8. Let the system run until the vacuum gauge shows a good vacuum through the cooling system. Refer to the tool's operating manual for appropriate pressure readings.
9. Close the vacuum generator / venturi ball valve.

10. Disconnect the vacuum generator / venturi and airline (1) from the adaptor cone/vacuum gauge assembly (2).

11. Wait approximately 20 seconds, if the pressure readings do not move, the system has no leaks. If the pressure readings move, a leak could be present in the system. Check for leaks and repeat the procedure.

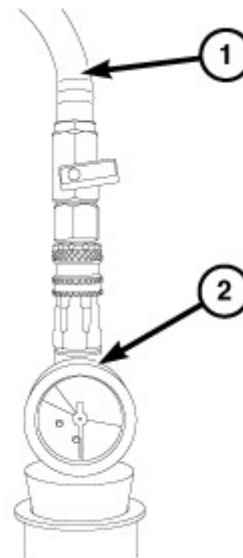

2321184

NOTE: Ensure there is a sufficient amount of coolant, mixed to the required strength/protection level available for use. For best results and to assist the refilling procedure, place the coolant container at the same height as the filler neck. Always draw more coolant than required. If the coolant level is too low, it will pull air into the cooling system which could result in air locks within the system.

12. Place the tool's suction hose into the coolant's container.

NOTE: Typical view of coolant refilling procedure.

13. Connect the tool's suction hose (1) to the adaptor cone/vacuum gauge assembly (2).

14. Open the suction hose's ball valve to begin filling the cooling system.

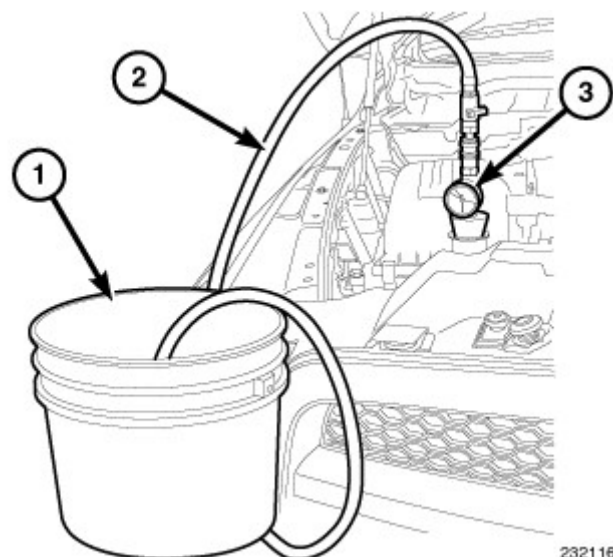

2321168

NOTE: If filling through a pressurized coolant bottle, stop filling when the proper level is reached.

15. When the vacuum gauge reads zero, the system is filled.
16. Close the suction hose's ball valve and remove the suction hose from the adaptor cone/vacuum gauge assembly.
17. Remove the adaptor cone/vacuum gauge assembly from the filler neck.
18. Install the cap on the filler neck.
19. Start and run the engine with the heater control unit in the HEAT position.
20. After the engine has reached normal operating temperature, shut the engine off and allow it to cool. When the engine is cooling down, coolant will be drawn into the radiator.

NOTE: Only add coolant to the container when the engine is cold. Warm engine coolant level will be higher due to thermal expansion.

21. Once the appropriate coolant level is achieved, install the cap on the filler neck.

07 - Cooling/Standard Procedure

ADDING ADDITIONAL COOLANT

WARNING:

ANTIFREEZE IS AN ETHYLENE GLYCOL BASE COOLANT AND IS HARMFUL IF SWALLOWED OR INHALED. IF SWALLOWED, DRINK TWO GLASSES OF WATER AND INDUCE VOMITING. IF INHALED, MOVE TO FRESH AIR AREA. SEEK MEDICAL ATTENTION IMMEDIATELY. DO NOT STORE IN OPEN OR UNMARKED CONTAINERS. WASH SKIN AND CLOTHING THOROUGHLY AFTER COMING IN CONTACT WITH ETHYLENE GLYCOL. KEEP OUT OF REACH OF CHILDREN. DISPOSE OF GLYCOL BASED COOLANT PROPERLY. CONTACT YOUR DEALER OR GOVERNMENT AGENCY FOR LOCATION OF COLLECTION CENTER IN YOUR AREA. DO NOT OPEN A COOLING SYSTEM WHEN THE ENGINE IS AT OPERATING TEMPERATURE OR HOT UNDER PRESSURE; PERSONAL INJURY CAN RESULT. AVOID RADIATOR COOLING FAN WHEN ENGINE COMPARTMENT RELATED SERVICE IS PERFORMED; PERSONAL INJURY CAN RESULT.

CAUTION: If customer returned the vehicle with coolant lower than the minimum fill line, all 4 O-rings at the turbo to oil and coolant tubes must be replaced.

- Only use specified coolant type designed for this vehicle ([Refer to 04 - Vehicle Quick Reference/Capacities and Recommended Fluids/Specifications](#)).
- When additional coolant is needed, the engine MUST be cold and add enough coolant/distilled water to the Pressurized Coolant Bottle to set the level between the MIN (Add) and MAX (Full) indicators on the bottle.

07 - Cooling/Standard Procedure

CLIC© HOSE CLAMP PLIERS - USAGE

Special Tools: Click to hide the list of tools used in this procedure

[Click here to launch the form to order any tools you need.](#)

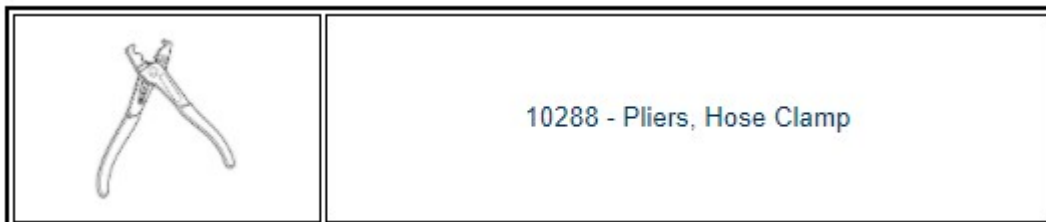

When CLIC© style clamps are used in the cooling system, use Special Tool [Pliers, Hose Clamp 10288](#) or equivalent, for proper installation and removal of the clamps.

Installation of the hose clamp requires the flat blade of the pliers to rest against the latch lock side of the clamp. The notched end of the pliers will be positioned on the protruded guide on the latch side. Squeeze the pliers until a **CLICK** sound is heard.



3511532

Removal of the hose clamp requires the notched end of the pliers to rest against the latch side of the clamp. Squeezing the pliers will cause the hook of the latch lock to ride up the beveled edging of the notched side, releasing itself from the lock.

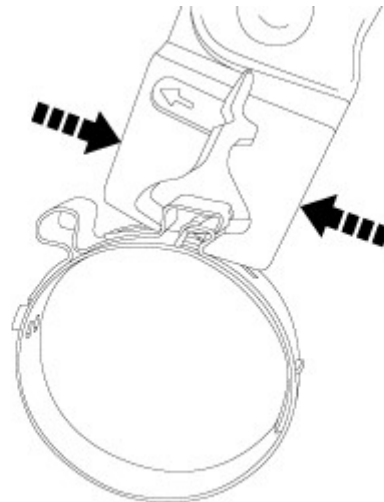

3515155

07 - Cooling/Standard Procedure

REVERSE FLUSHING

CAUTION: The cooling system normally operates at 97-124 kPa (14-18 psi) pressure. Exceeding this pressure may damage the radiator or hoses.

Reverse flushing of the cooling system is the forcing of water through the cooling system. This is done using air pressure in the opposite direction of normal coolant flow. It is usually only necessary with very dirty systems with evidence of partial plugging.

CHEMICAL CLEANING

CAUTION: Be sure instructions on the container are followed.

If visual inspection indicates the formation of sludge or scaly deposits, use a radiator cleaner (Mopar Radiator Kleen or equivalent) before flushing. This will soften scale and other deposits and aid the flushing operation.

Make sure to follow the cleaner directions for best results.

REVERSE FLUSHING RADIATOR

CAUTION: The cooling system normally operates at 97-124 kPa (14-18 psi) pressure. Exceeding this pressure may damage the radiator or hoses.

- Disconnect the radiator hoses from the radiator fittings. Attach a section of radiator hose to the radiator bottom outlet fitting and insert the flushing gun. Connect a water supply hose and air supply hose to the flushing gun.
- Allow the radiator to fill with water. When radiator is filled, apply air in short blasts allowing radiator to refill between blasts. Continue this reverse flushing until clean water flows out through rear of radiator cooling tube passages. For more information, refer to operating instructions supplied with flushing equipment.

REVERSE FLUSHING ENGINE / RADIATOR

1. Drain the cooling system ([Refer to 07 - Cooling - Standard Procedure](#)).
2. Install a thermostat housing that has had the thermostat removed ([Refer to 07 - Cooling/Engine/THERMOSTAT/Removal and Installation](#)).
3. Disconnect the radiator upper hose from the radiator and attach the flushing gun to the radiator upper hose.
4. Disconnect the radiator lower hose from the radiator and attach the drain hose to the lower radiator hose.
5. Connect the water supply hose and air supply hose to the flushing gun.

6. Allow the engine to fill with water. When the engine is filled, apply air in short blasts, allowing the system to fill between air blasts. Continue until clean water flows from the drain hose.

7. For more information, refer to operating instructions supplied with flushing equipment.

8. Remove the drain hose, flushing gun, water supply hose, and air supply hose.

9. Remove the thermostat housing that has had the thermostat removed and install a **NEW** thermostat and housing with a replacement gasket ([Refer to 07 - Cooling/Engine/THERMOSTAT/Removal and Installation](#)).

10. With the radiator hoses removed from radiator inlet and outlet, attach a section of radiator hose to radiator bottom outlet fitting and insert flushing gun. Connect a water supply hose and air supply hose to flushing gun.

11. Allow radiator to fill with water. When radiator is filled, apply air in short blasts allowing radiator to refill between blasts. Continue this reverse flushing until clean water flows out through the upper inlet fitting.

12. Connect the radiator hoses. Refill the cooling system with the correct antifreeze/water mixture ([Refer to 07 - Cooling - Standard Procedure](#)).