

FIAT
GROUP

Engines and Transmissions

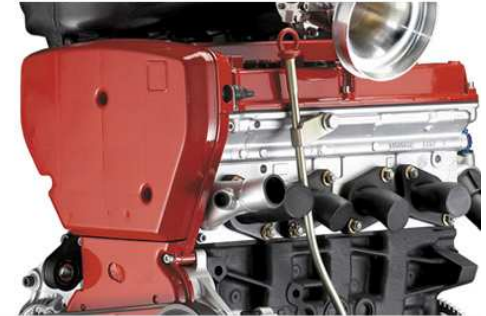

FIRE Multiair engines: NA 105 CV and TC 135 CV & 170 CV

Sistema UNIAIR - Principi Funzionamento

- **FIRE 1.4 16V MAIR architecture**
- UNIAIR basic principles
- UNIAIR's main components
- UNIAIR system interfaces
- Oil supply circuits
- UNIAIR System: valve lift characteristics

FIRE 1.4 16V MAIR architecture - ALPHA Lay-out

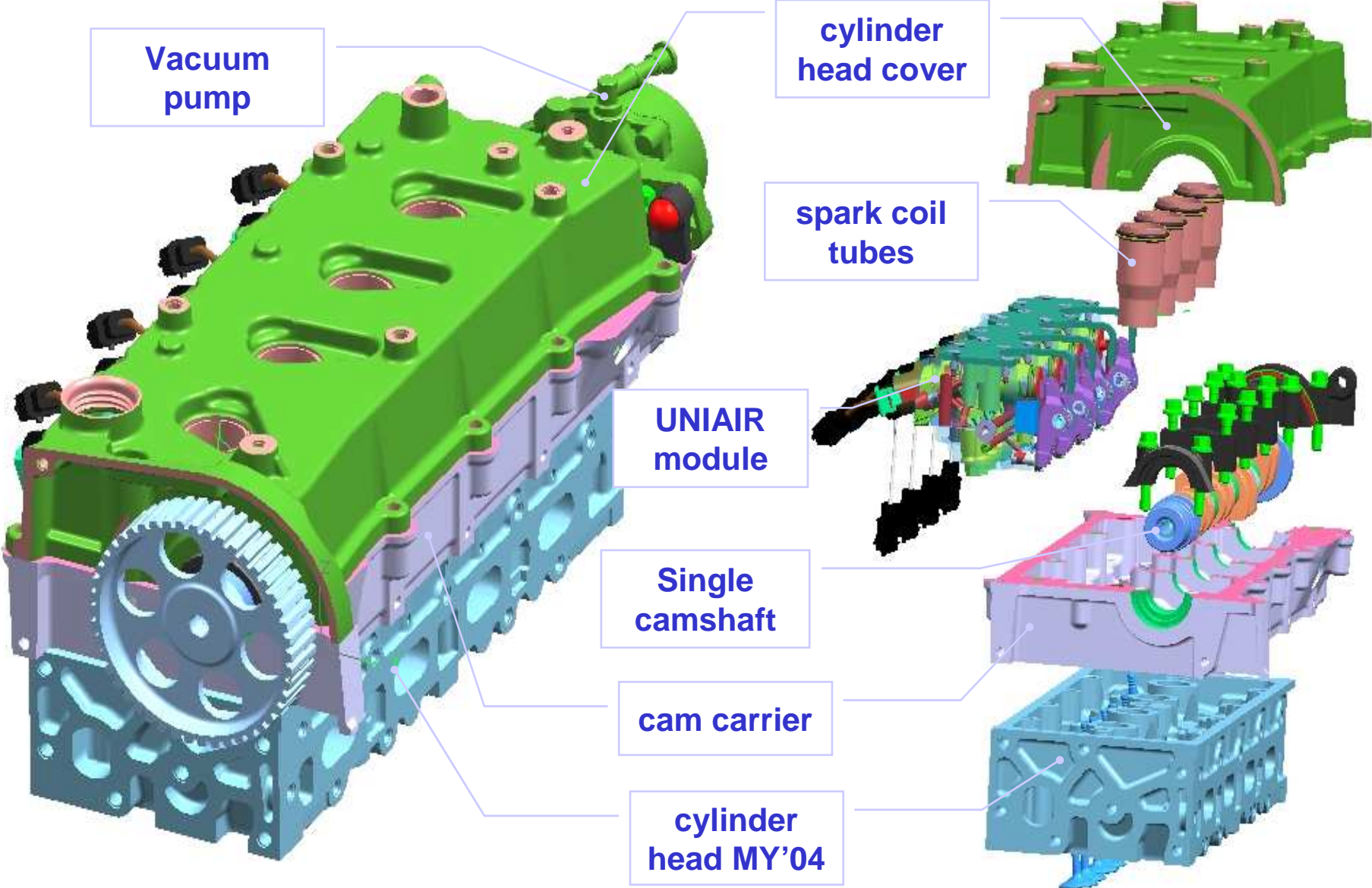

FIRE 1.4 16V MAIR architecture - BETA Lay-out

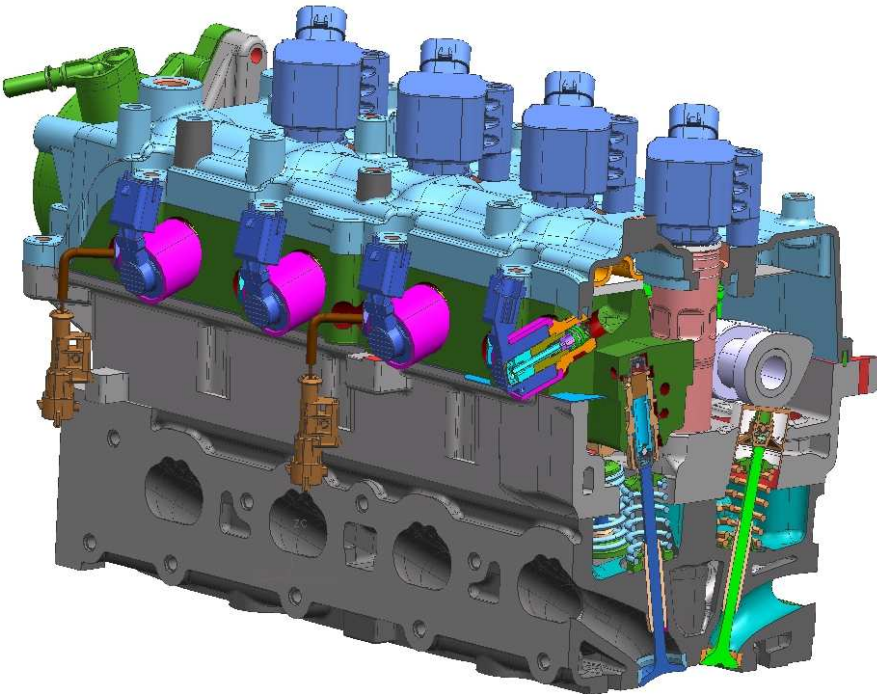

TOP WORK

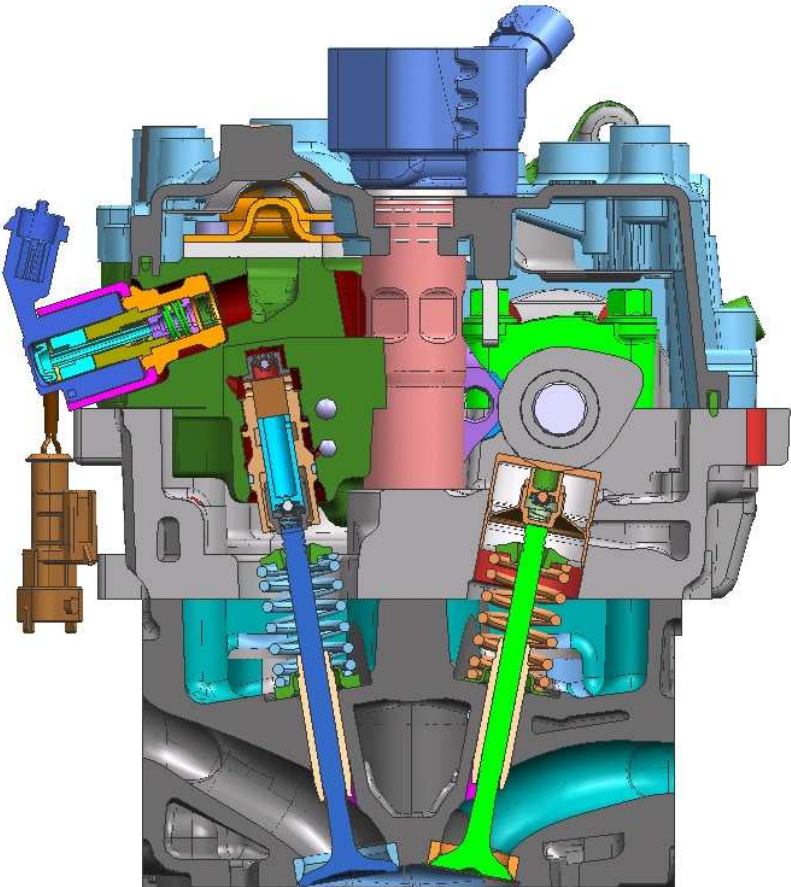

FIRE 1.4 16V MAIR architecture - BETA Lay-out

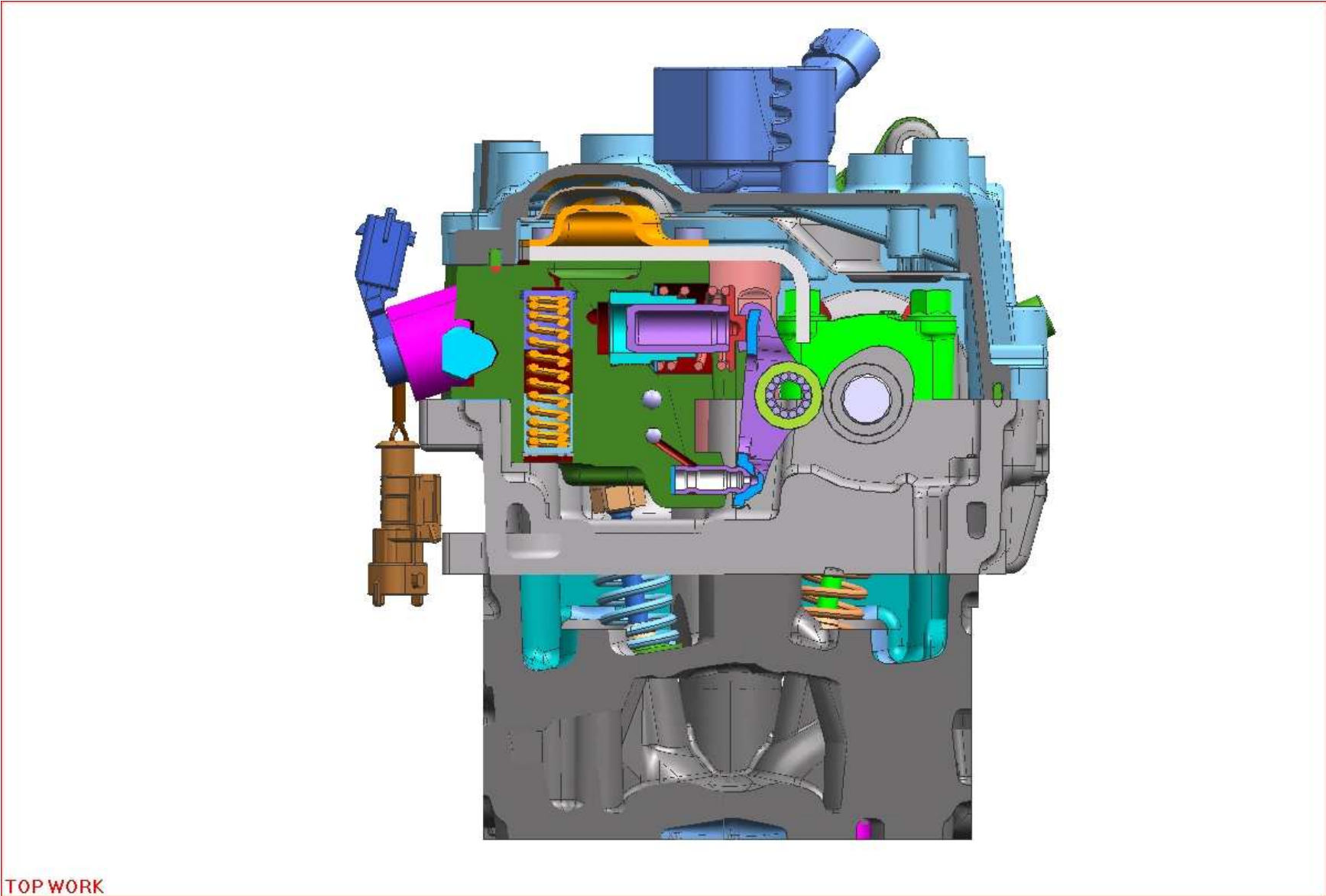

TOP WORK

FIRE 1.4 16V MAIR architecture - BETA Lay-out

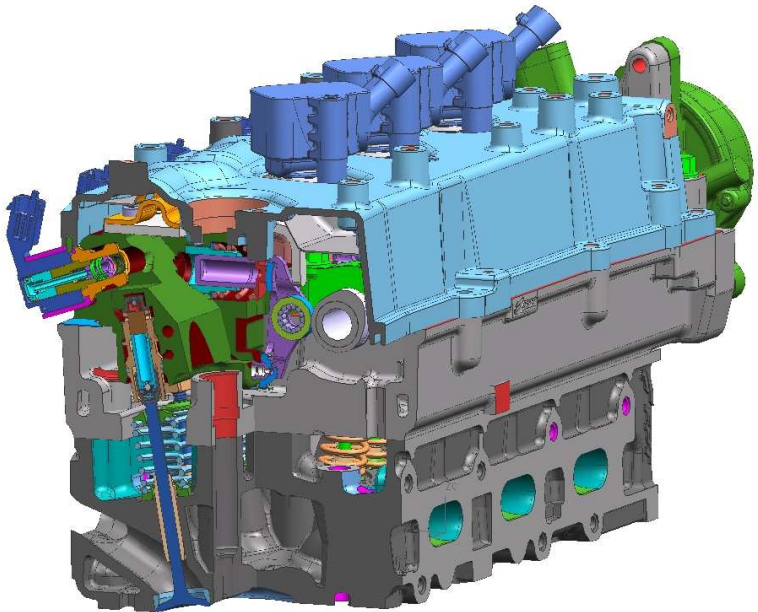
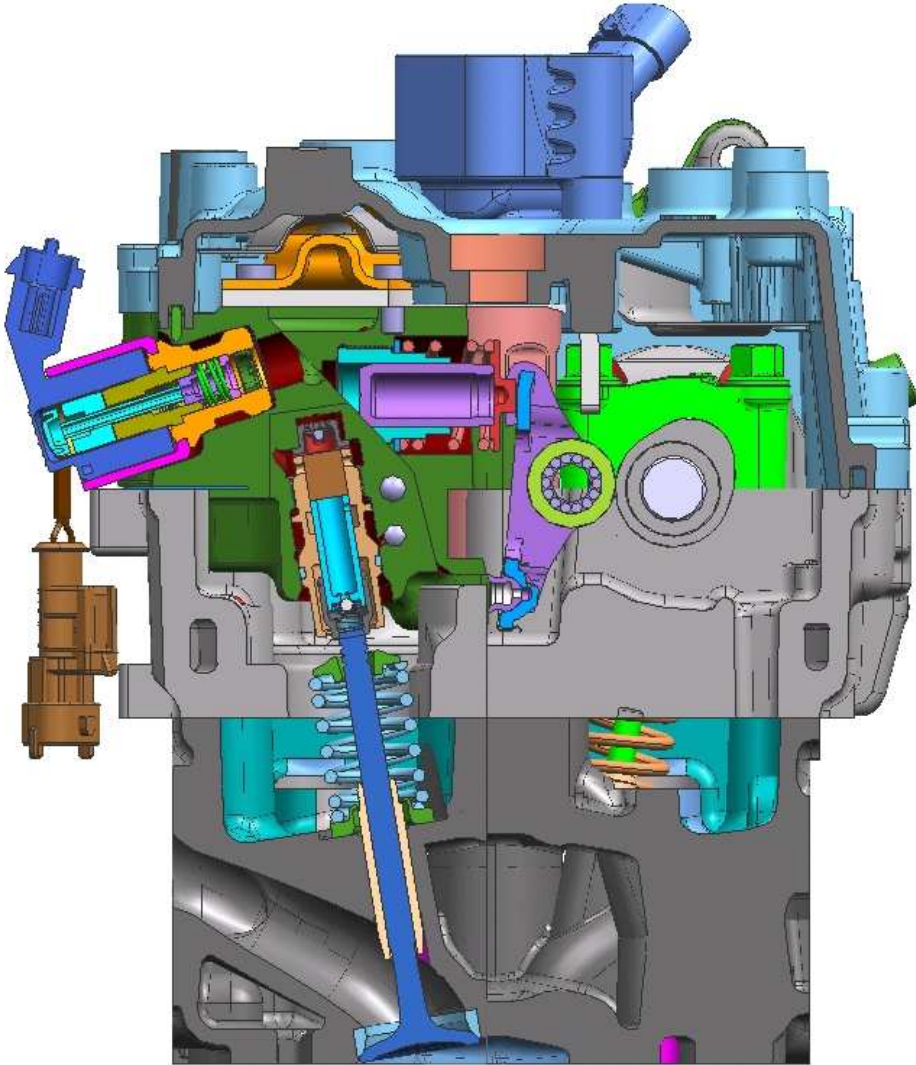

IK

- FIRE 1.4 16V MAIR architecture
- **UNIAIR basic principles**
- UNIAIR's main components
- UNIAIR system interfaces
- Oil supply circuits
- UNIAIR System: valve lift characteristics

FIRE Mair – NA (105CV) e TC (135/165CV) Euro5 versions

Multiair Actuator CAD model

BETA2 assembly: f-446306_30_m01_einb_asm.stp

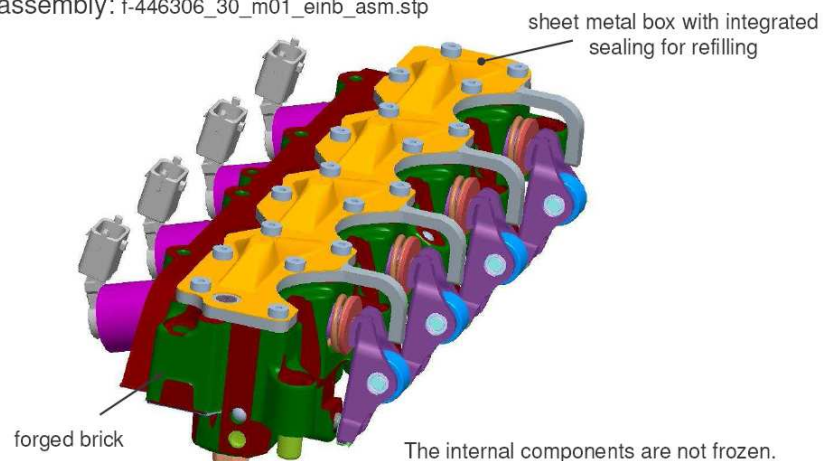

Air&Combustion Management system

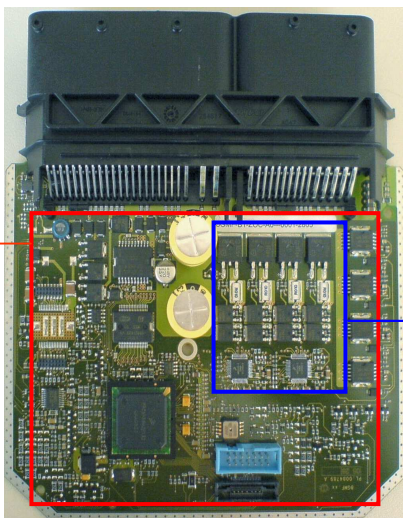

MULTI AIR ENGINE CONTROL:
ADVANCED AIR AND COMBUSTION CONTROL STRATEGIES (UNIAIR SPECIFIC)

UNIAIR ACTUATOR CONTROL:

- VALVE OPENING / CLOSING
- DIAGNOSIS
- OBD MONITORING

UNI AIR system and basic principles

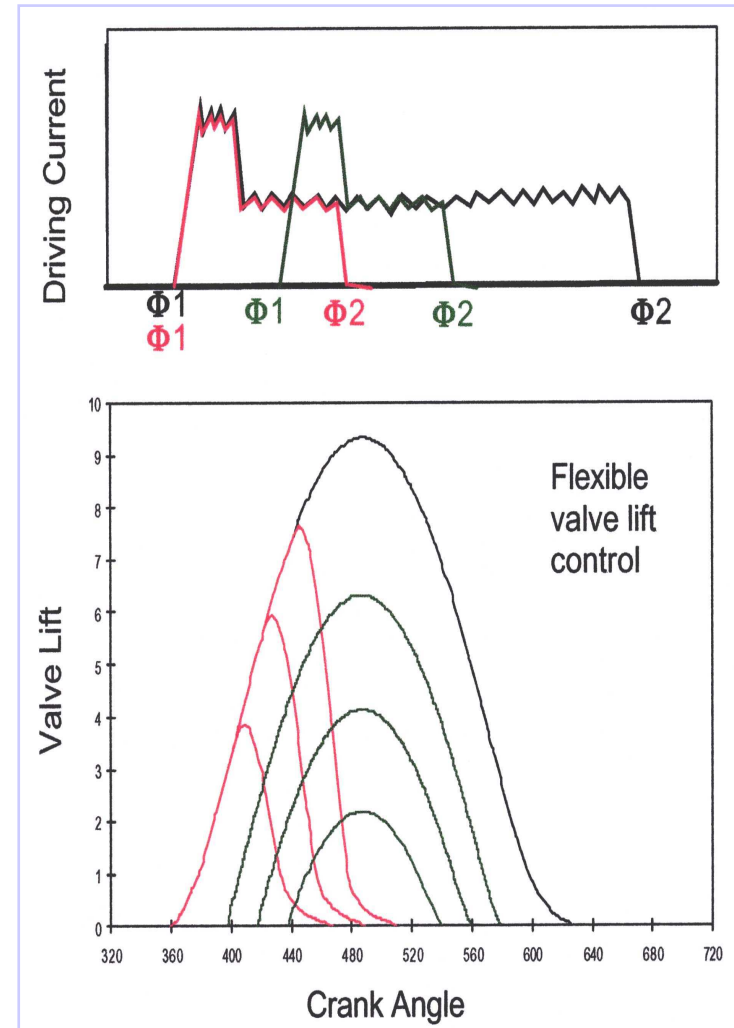
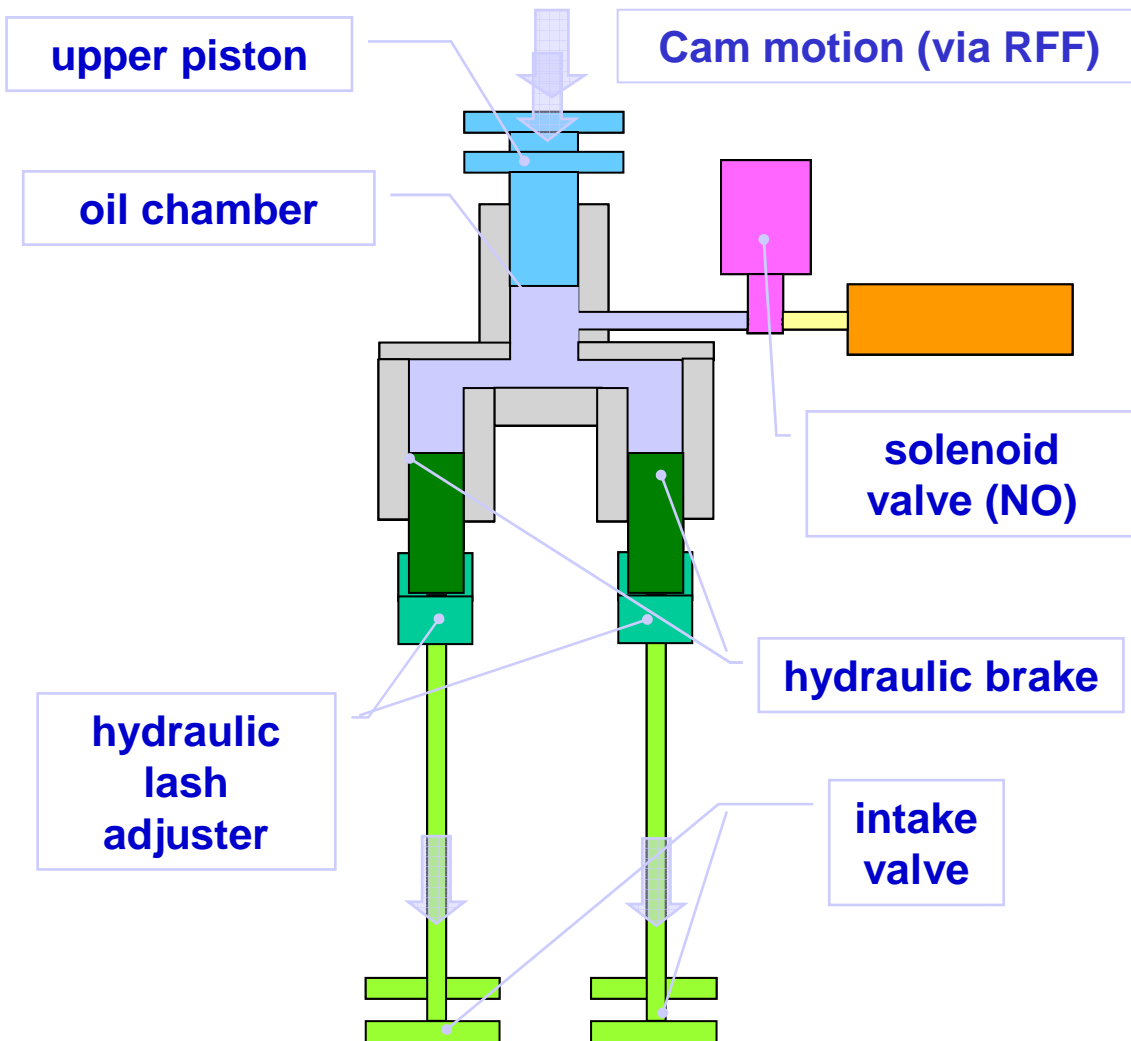

UNIAIR system and basic principles - Valve modes

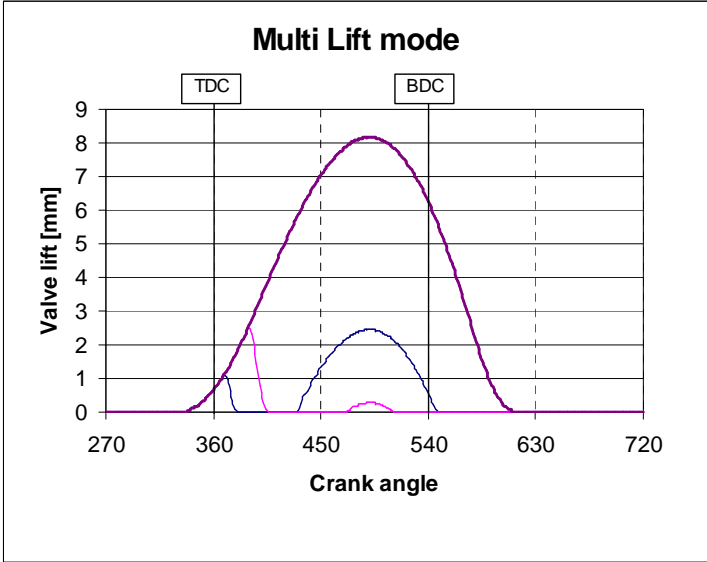
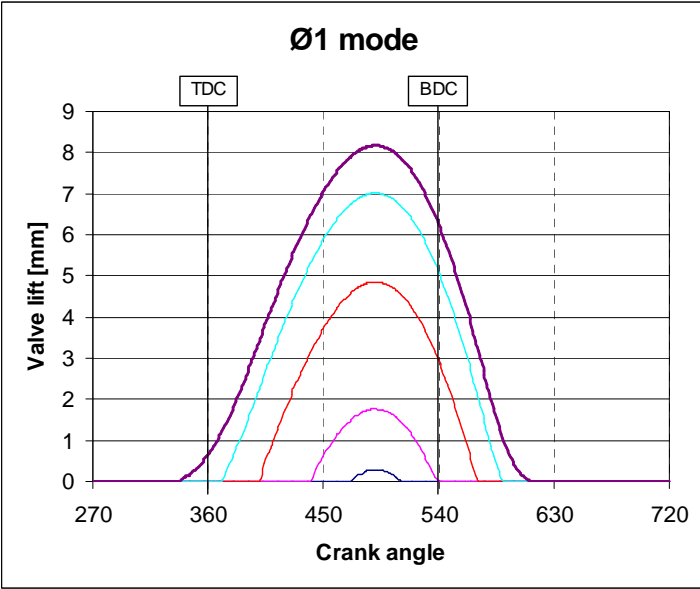
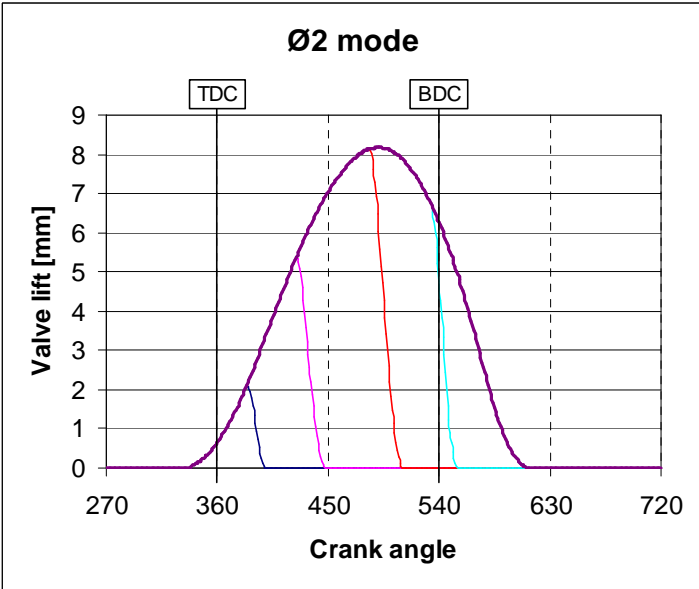

Uniair Technologies features & benefits

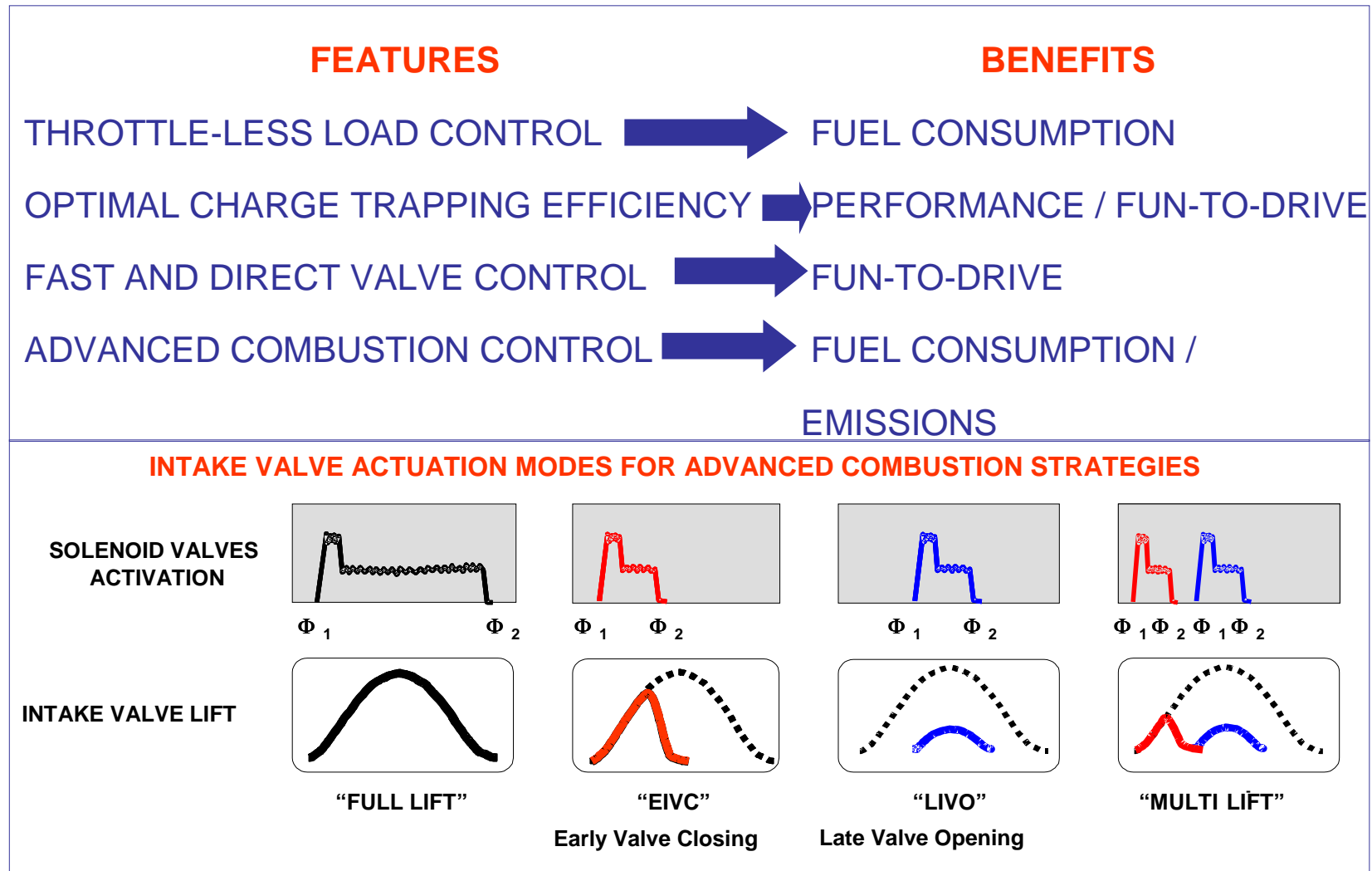

- FIRE 1.4 16V MAIR architecture
- UNIAIR basic principles
- **UNIAIR's main components**
- UNIAIR system interfaces
- Oil supply circuits
- UNIAIR System: valve lift characteristics

UNIAIR's main components

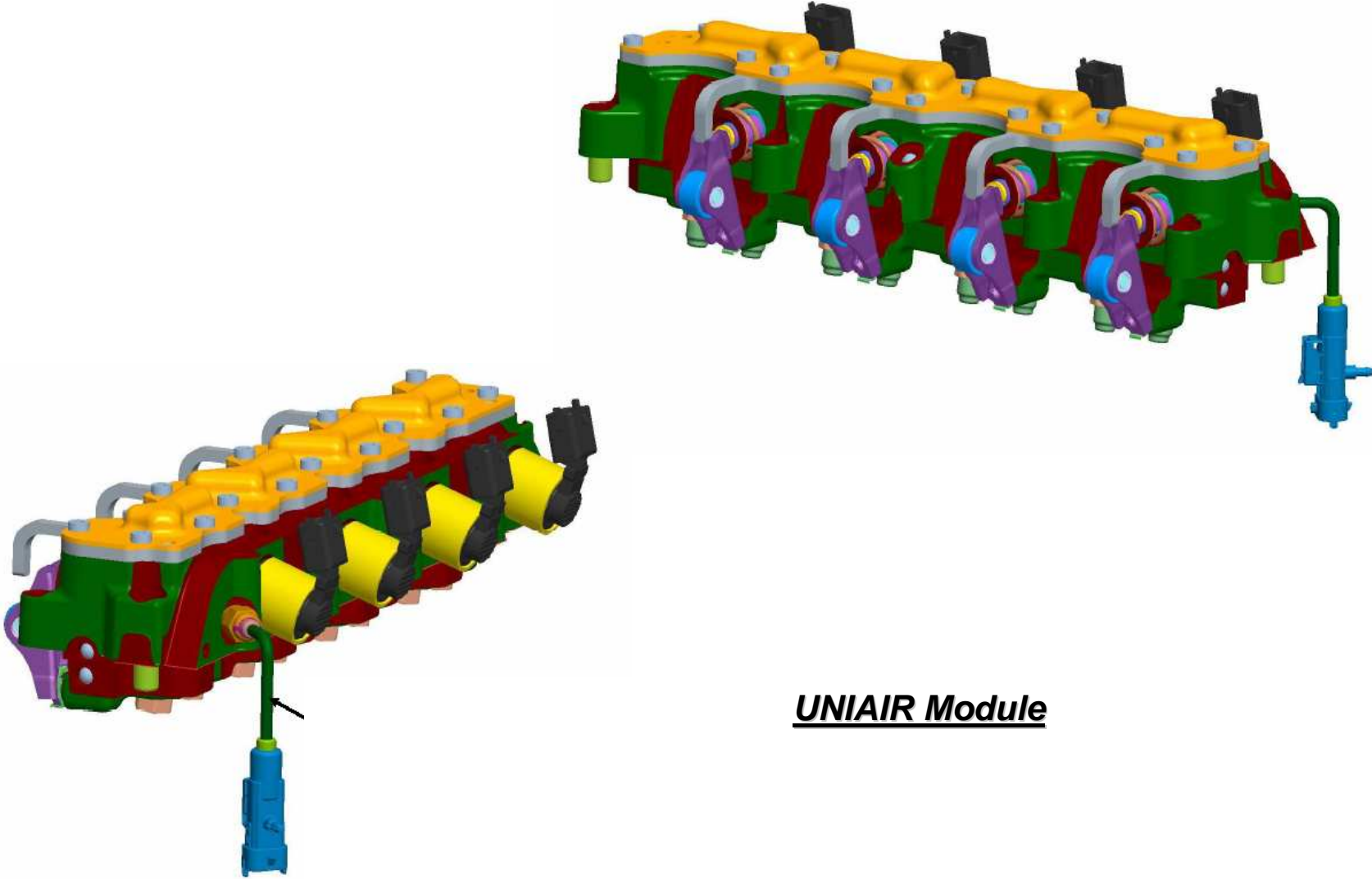

UNIAIR Module

UNIAIR's main components

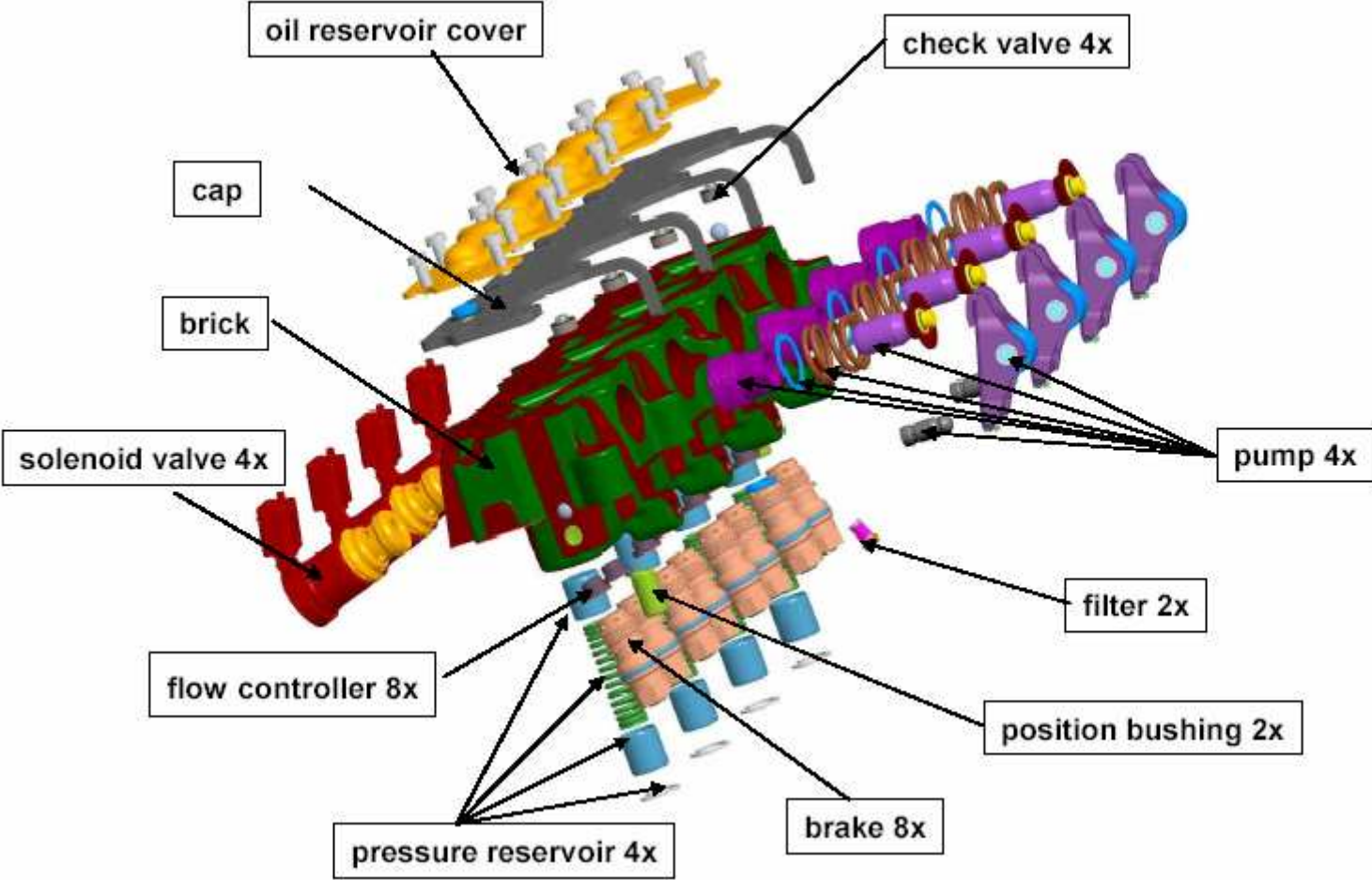

UNIAIR's main components

BETA3 pump piston fixation

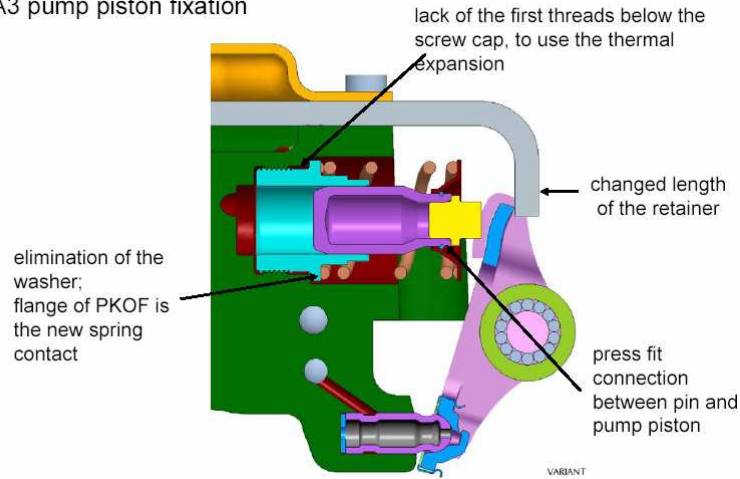

Pump Piston Unit

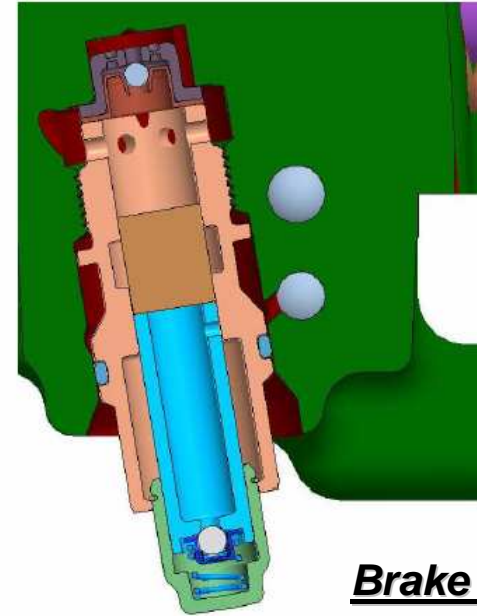

Brake Piston Unit

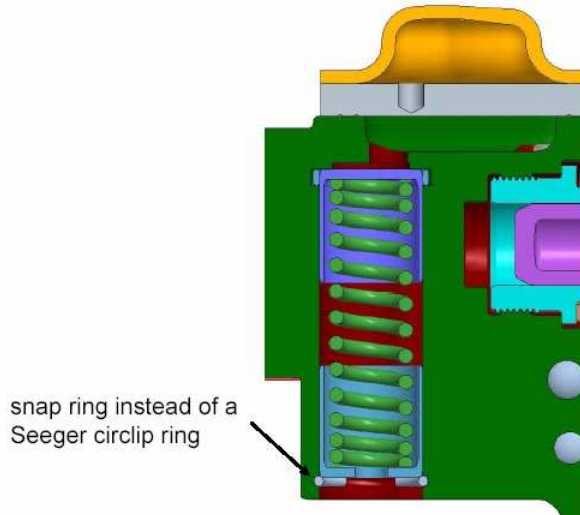

Pressure Accumulator



Solenoid Valve

- FIRE 1.4 16V MAIR architecture
- UNIAIR basic principles
- UNIAIR's main components
- **UNIAIR system interfaces**
- Oil supply circuits
- UNIAIR System: valve lift characteristics

- **Electrical interfaces:**
 - N. 4 solenoid connectors
 - N. 1 NTC oil temperature sensor connector

- **Mechanical interfaces:**
 - Cam-carrier
 - Engine cover

- **Hydraulic interfaces from cam-carrier:**
 - Supply line for HLA and RFF lubrication
 - Supply line for VVA actuators

Timing Characterization of SV command



SV CURRENT

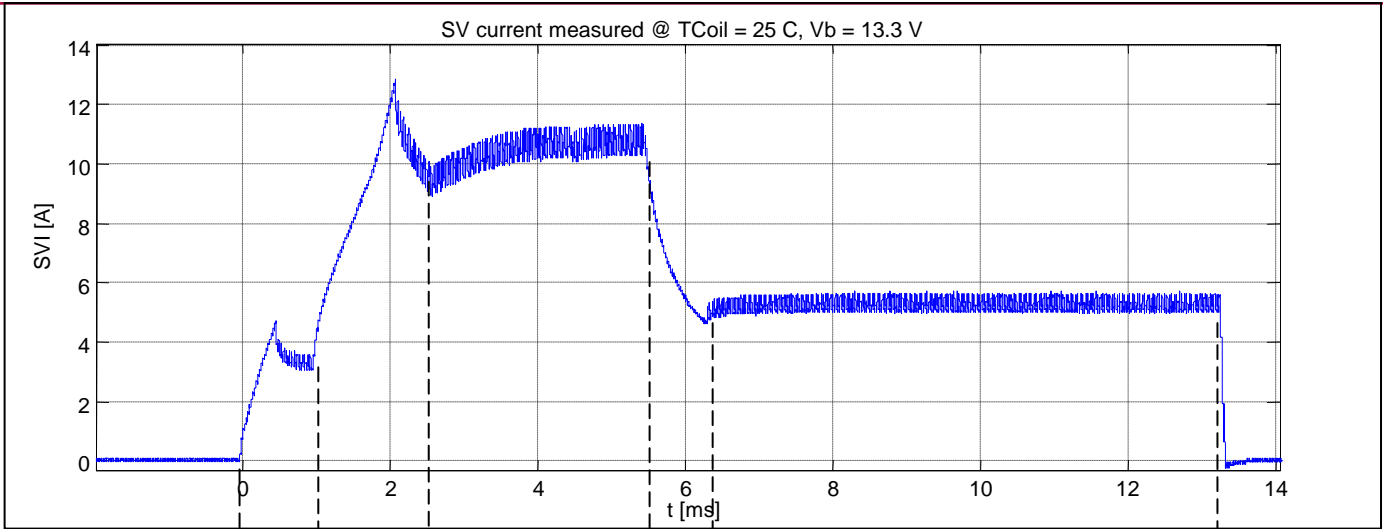

F = 30 kHz

Vpwr = 13.3 V

TIMING

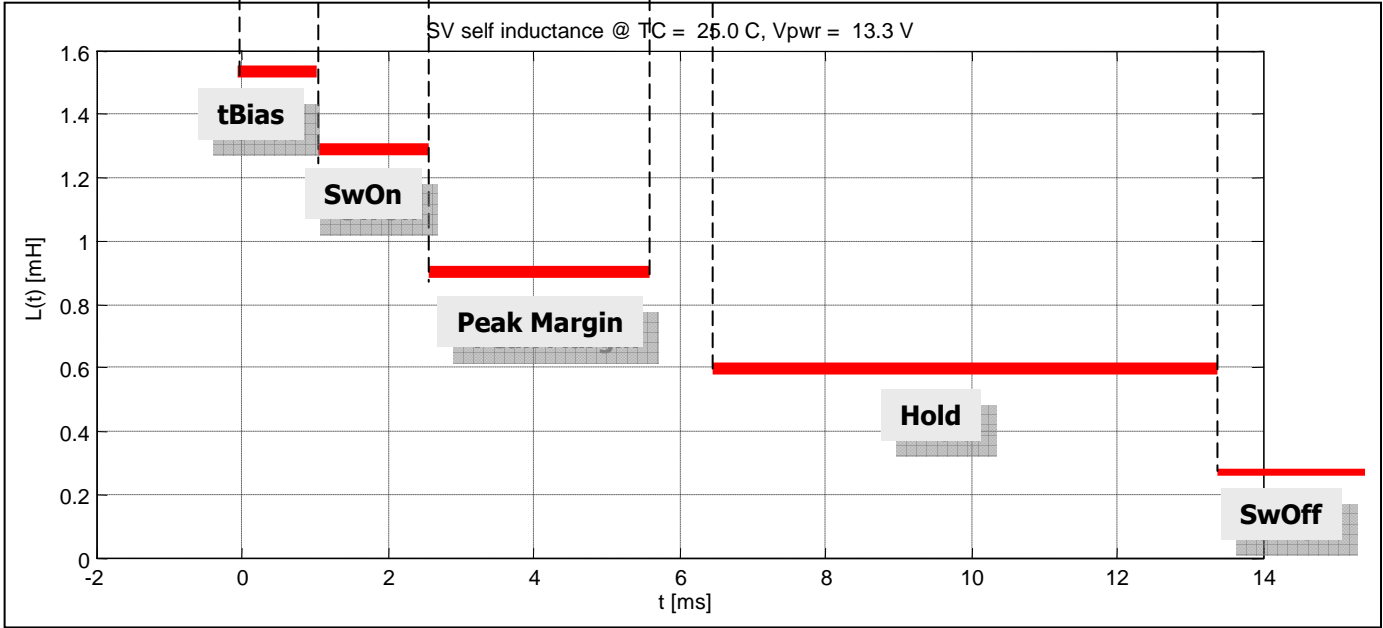

tBias = 0.7ms

SwOn = 1.5 ms ±0.2
@ 90°C
50bar
Q 5 l/min ms ±0.2

Peak Margin = 0.5 ms
@ 13 V
20°C

Hold = {rpm, req. angle}

SwOff = 1ms ±0.2
@ 90°C
50bar
Q 5 l/min

- FIRE 1.4 16V MAIR architecture
- UNIAIR basic principles
- UNIAIR's main components
- UNIAIR system interfaces
- **Oil supply circuits**
- UNIAIR System: valve lift characteristics

Oil supply circuits

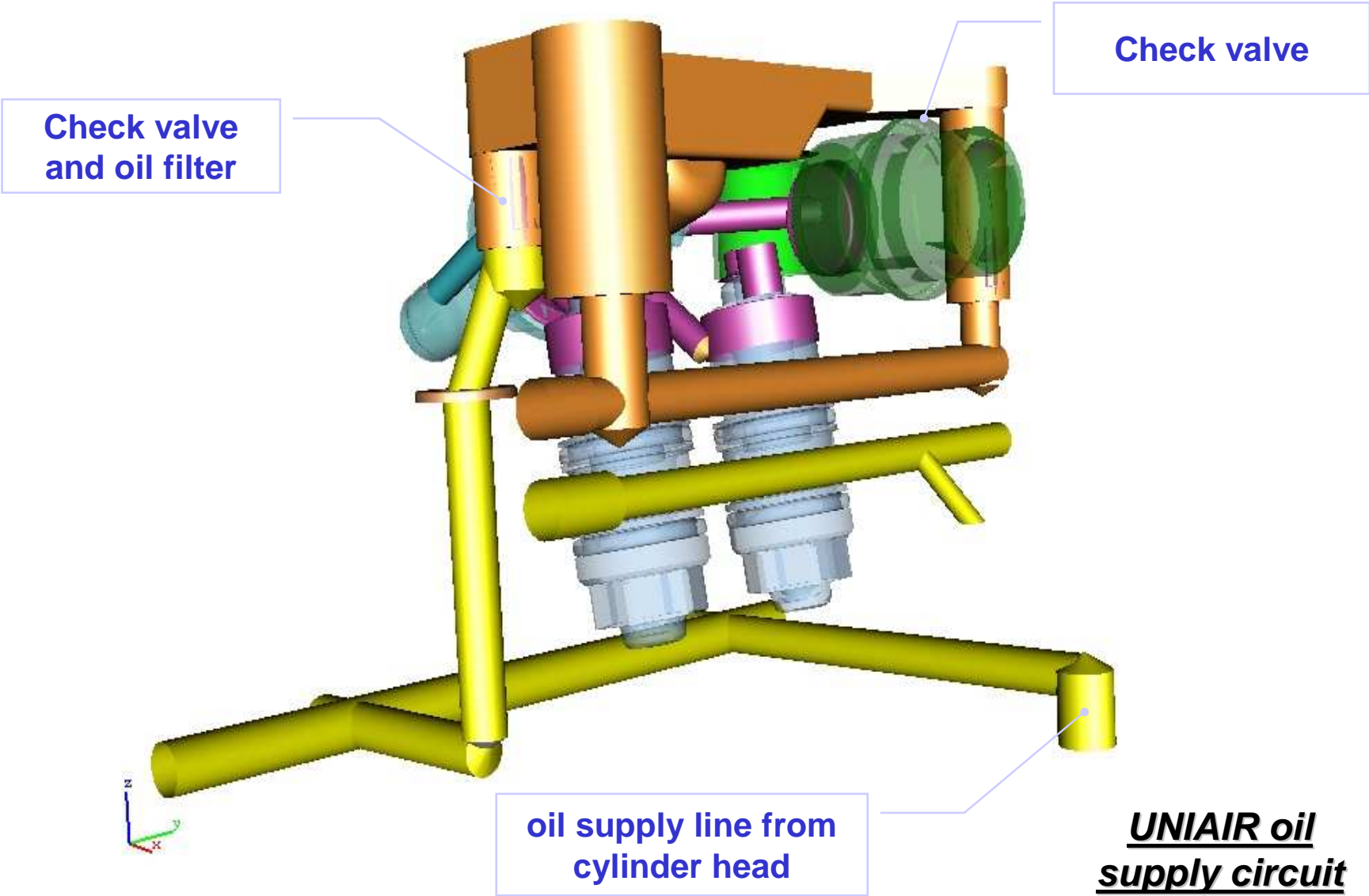

UNIAIR oil supply circuit

Oil supply circuits



roller finger follower
pivot
&
hydraulic lash
adjuster

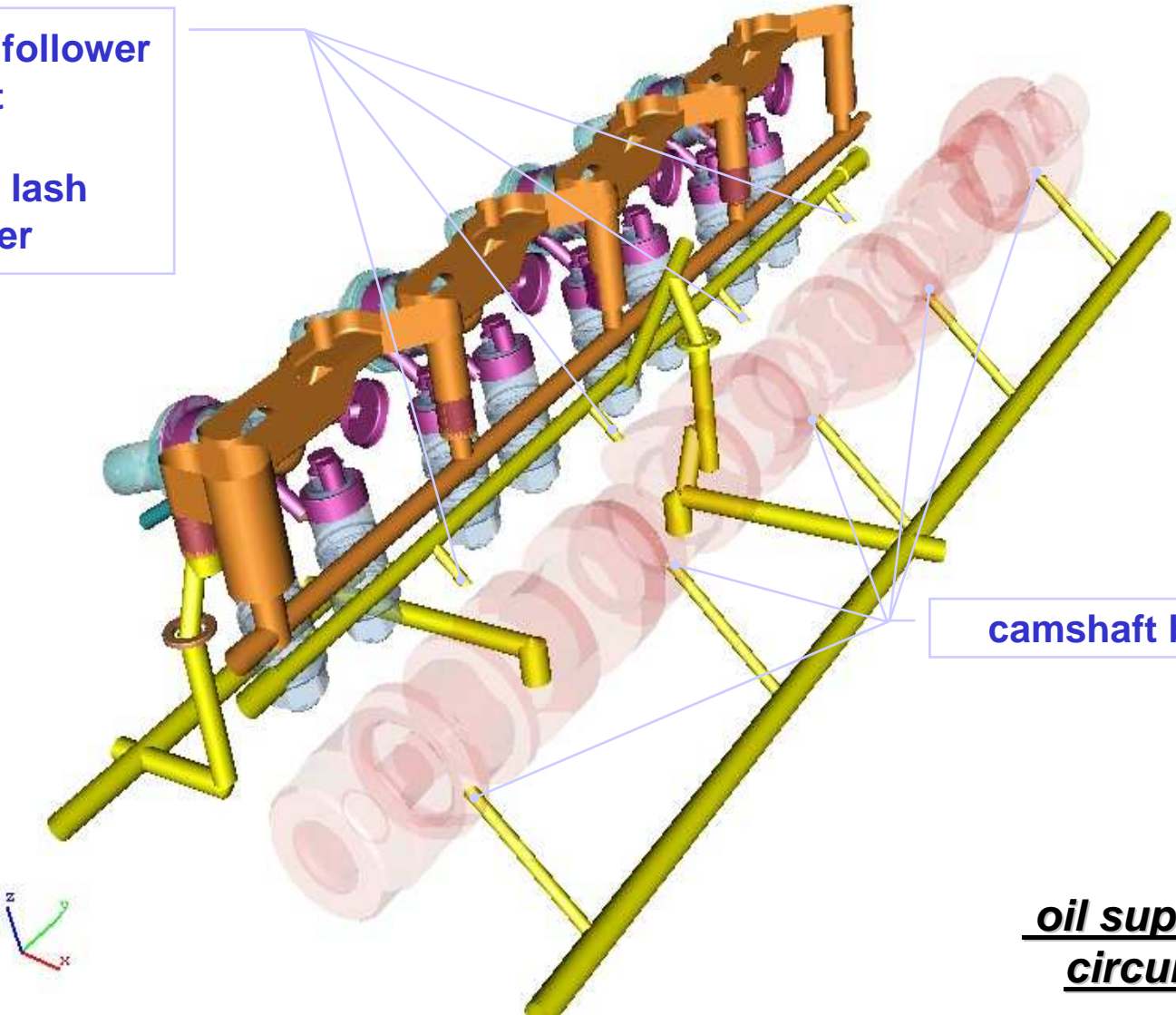

camshaft bearing

oil supply
circuit

Oil supply circuits

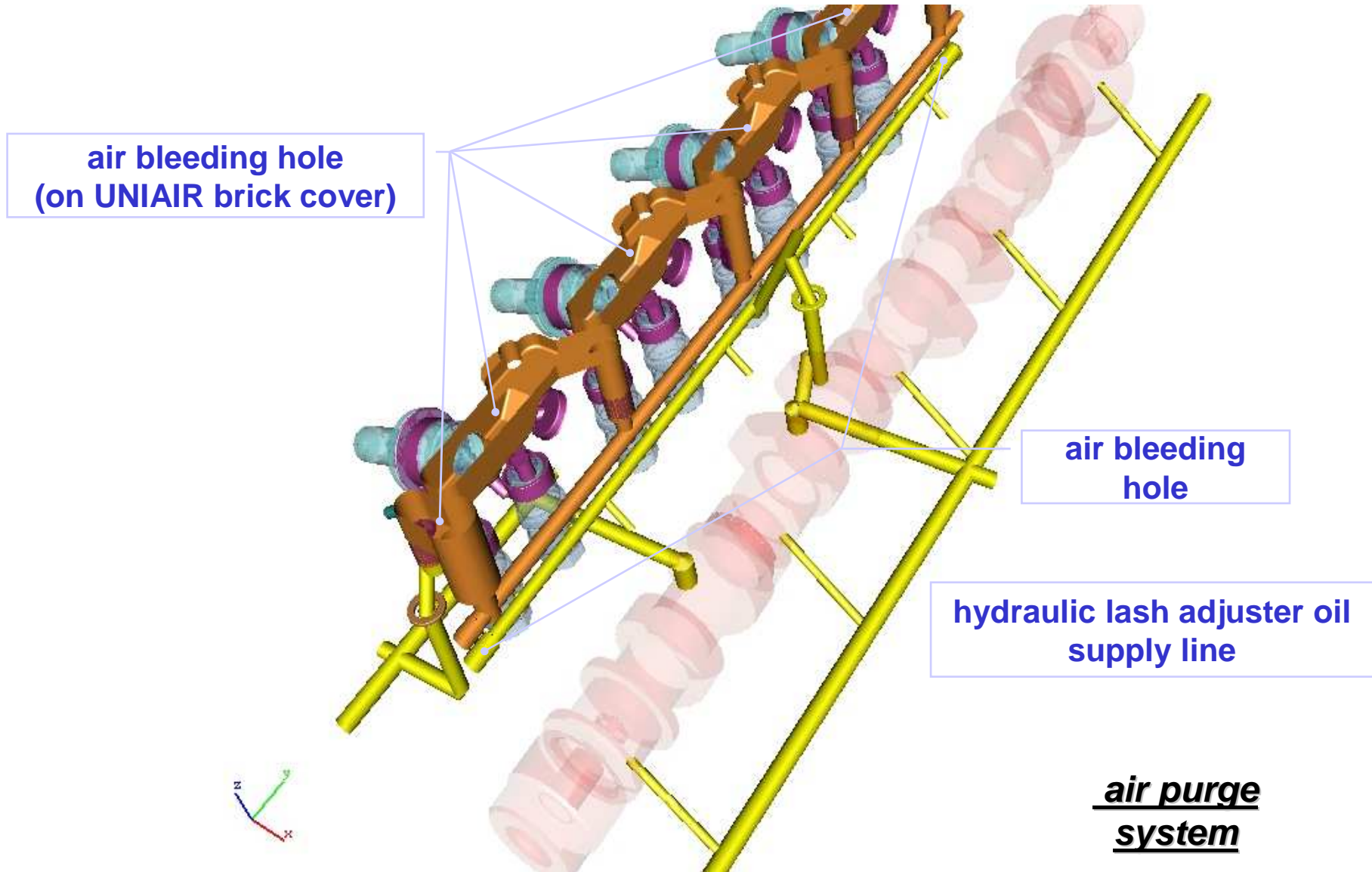

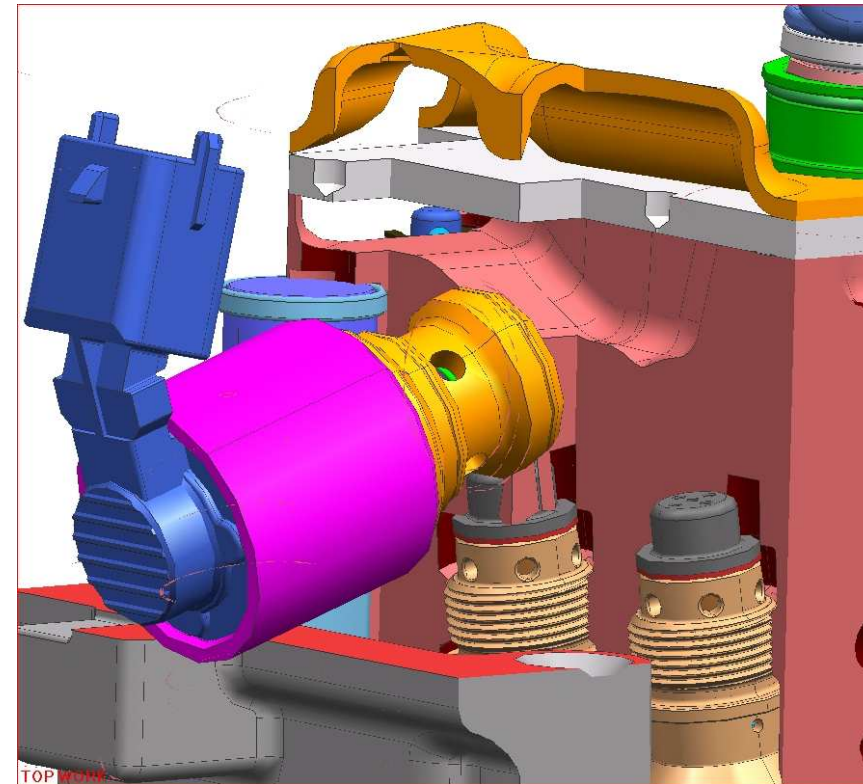
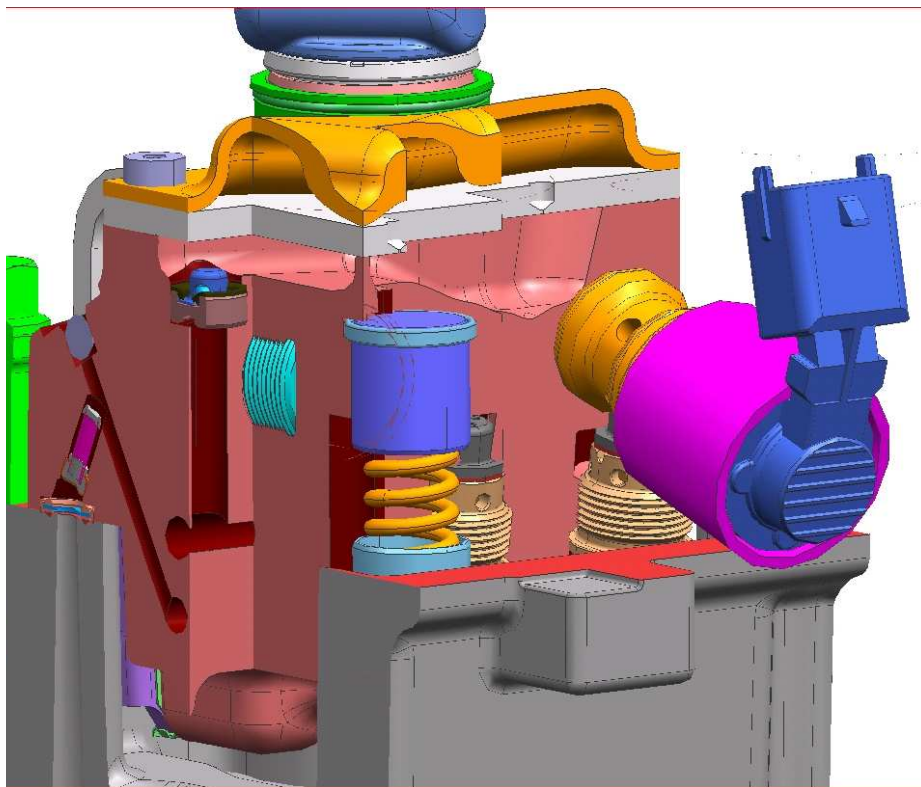

air purge system and oil volume

- FIRE 1.4 16V MAIR architecture
- UNIAIR basic principles
- UNIAIR's main components
- UNIAIR system interfaces
- Oil supply circuits
- **UNIAIR System: valve lift characteristics**

UNIAIR System: valve lift characteristics

EVC characteristic



Testa NA B2 Master - Beta 0 Brick 018 - Toil 90°C Poil 2.5 bar (SAE 5W40)V

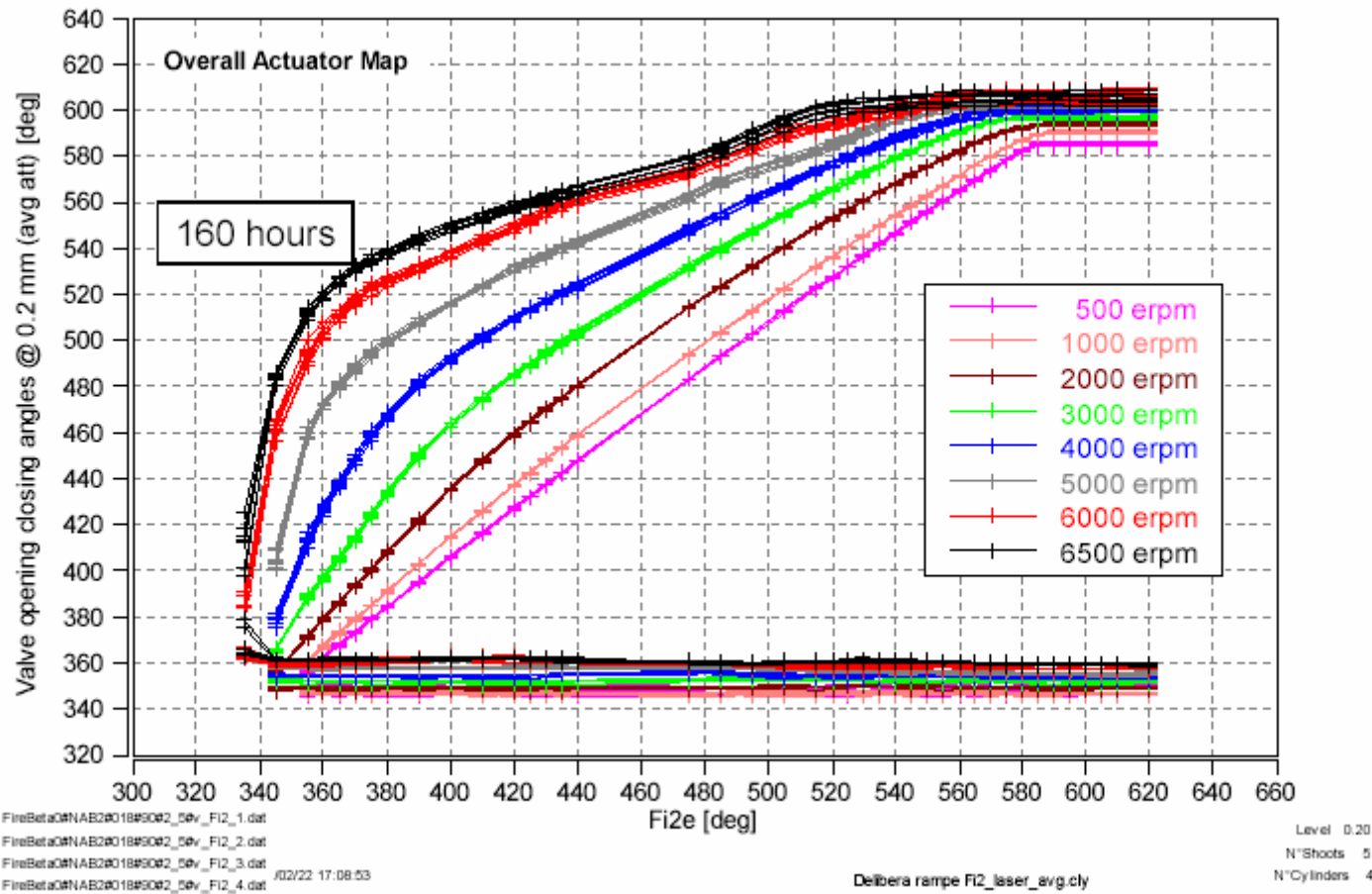

UNIAIR System: valve lift characteristics

EVC characteristic



Testa NA B2 Master - Beta 0 Brick 018 - Toil 90°C Poil 2.5 bar (SAE 5W40)V

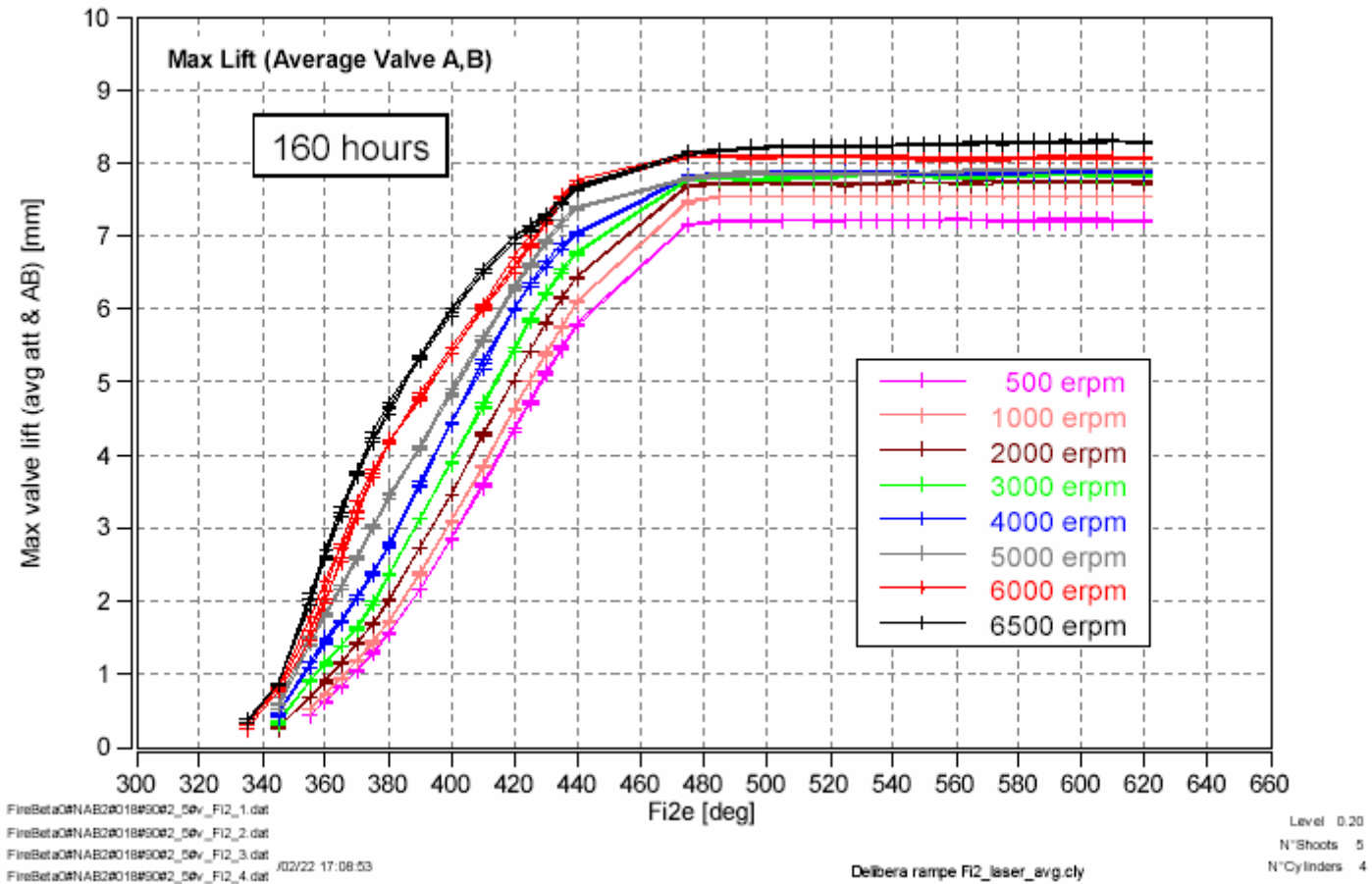

UNIAIR System: valve lift characteristics

LVO characteristic

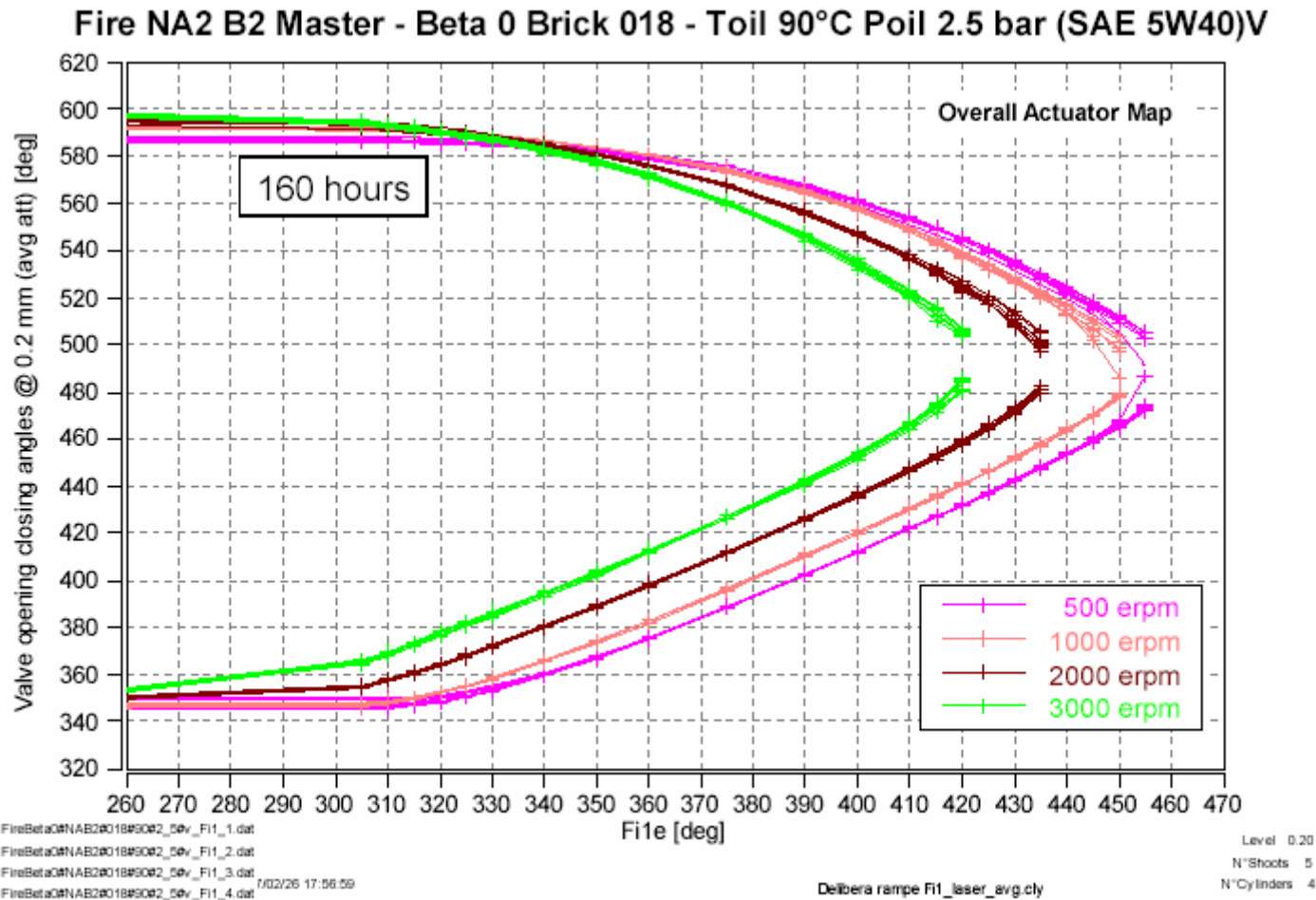

UNIAIR System: valve lift characteristics

LVO characteristic



Fire NA2 B2 Master - Beta 0 Brick 018 - Toil 90°C Poil 2.5 bar (SAE 5W40)V

